

الموضوع :

(1970-2001)

(2002-2006)

_____ :

..... :

:

.....(،) :
.....(،)..... :
مناقشا(،)..... :
مناقشا(،)..... :
مناقشا(،)..... :
.....(،) :

2005/2004 :

⋮

•

:

,

:

.

:

.

(

-

)

:

.

:

.

_____:

56	ARIMA	1
71		2
72	()	3
73	2003 1990	4
73	()	5
84	2003 - 1970	6
86	2003 - 1970	7
96	GRANGER	8
102		9
121		10
121	2SLS OLS	11
128		12
132		13
136		14
138		15
142		16
145		17
148		18
148	2003 2002	19
149		20
153		21
166		22
167		23

IV

: _____

02		1
04		2
04		3
06		4
08		5
09		6
31		7
33		8
36		9
48-46		10
49	-	11
52		12
57		13
74		15
75	()	16
75	()	17
76	()	18
77	()	19
77	()	20
78	()	21
79	()	22
80	()	23
81	()	24
82	()	25
82	()	26
83	()	27
83	()	28

84	()	29
85	()	30
87	()	31
87	()	32
88	()	33
90	()	34
91		35
92		36
92		37
124		38
125		39
126		40
127		41
129		42
133		43

VI

_____:

187	(2003 -1994)	01
191	(2001 -1970)	02
194		03
195	(2001-1999)	04

(2001 - 1994)

: (01)

BUDGET DE L'ETAT.**(EN MILLIARDS DE DA).**

	<u>1994</u>	<u>1995</u>	<u>1996</u>	<u>1997</u>	<u>1998</u>	<u>1999</u>
<u>Recettes budgétaires</u>	477.2	611.7	824.0	933.6	784.3	972.8
Recettes fiscales	176.2	242.0	286.9	312.9	338.5	338.9
Recettes ordinaires	10.6	10.7	14.0	17.9	15.7	14.6
Fiscalité pétrolière	222.2	336.1	496.2	570.8	378.7	560.1
Recettes exceptionnelles	68.2	22.9	26.8	32.1	51.4	55.2
Fonds de concours, dons et legs	0.0	0.0	0.0	0.0	0.0	3.9
<u>Dépenses budgétaires</u>	566.3	759.6	888.3	940.9	970.7	1078.8
Dépenses de fonctionnement	330.4	473.7	590.5	665.2	725.0	824.4
Dépenses d'équipement	235.9	285.9	297.8	275.7	245.7	254.4
Solde budgétaire	-89.1	-147.9	-64.3	-7.3	-186.4	-106.0
Solde budgét. hors dette pub.	-89.1	-147.9	-64.3	27.8	-101.3	9.9
Solde budgét. hors FA et dette publique	33.4	0.6	60.1	105.8	-101.3	9.9

FA= Fonds d'assainissement des entreprises publiques.

	<u>2000</u>	<u>2001</u>	<u>2002</u>	<u>2003</u>
<u>Recettes budgétaires</u>	1138.9	1395.8	1570.3	1518.2
Recettes fiscales	3632.4	405.3	478.2	524.5
Recettes ordinaires	16.5	15.1	66.0	22.2
Fiscalité pétrolière	720	840.6	916.4	836.1
Autres recettes	80	223.0	102.8	135.4
<u>Dépenses budgétaires</u>	1160.4	1519.3	1540.9	1786.8
Dépenses de fonctionnement	841.4	1056.8	1038.6	1173.8
Dépenses d'équipement	318.9	462.5	502.3	612.9
Solde budgétaire	-21.4	-123.5	29.4	-268.6
Solde budgét. hors dette pub.	<u>-21.4</u>	<u>-123.5</u>	29.4	-268.6
Solde budgét. hors FA et dette publique	<u>-21.4</u>	<u>-123.5</u>	<u>29.4</u>	<u>-268.6</u>

BALANCE DES PAIEMENTS.

(EN MILLIARDS DE US.\$).

	<u>1994</u>	<u>1995</u>	<u>1996</u>	<u>1997</u>	<u>1998</u>
Exportation de biens et snf	9.59	10.94	13.96	14.81	10.90
Hydrocarbures	8.61	9.73	12.64	13.25	9.75
Autres marchandises	0.29	0.53	0.57	0.50	0.37
Services	0.69	0.68	0.75	1.07	0.78
Importation de biens et snf	11.09	12.39	11.24	10.28	10.94
Biens	9.16	10.20	9.09	8.13	8.63
Services	1.93	2.19	2.15	2.15	2.31
Solde compte courant	-1.82	-2.52	0.93	3.01	-0.92
Solde compte capital	1.94	1.15	0.50	0.36	-0.25
Réserves brutes	2.64	2.11	4.23	8.05	6.84
Ratio du service de la dette ext.(%)	48.70	42.69	31.48	33.15	47.80

SITUATION MONETAIRE.

(EN MILLIARDS DE DA).

	<u>1994</u>	<u>1995</u>	<u>1996</u>	<u>1997</u>	<u>1998</u>	<u>1999</u>
Crédits à l'économie	305.8	565.6	776.8	741.3	906.2	1150.7
Crédits à l'Etat	468.5	401.6	280.5	423.7	723.2	847.9
Circulation fiduciaire	223.0	249.8	290.9	337.6	435.9	440.0
Dépôts à vue	252.8	269.3	298.2	333.9	422.9	465.2
Dépôts à terme	247.7	280.5	326.0	409.9	766.1	884.2
Masse monétaire M2	723.5	799.6	915.1	1081.5	1592.5	1789.4
Ratio de liquidité (%)	49.1	40.7	36.7	39.8	46.0	46.0

	<u>2000</u>	<u>2001</u>	<u>2002</u>	<u>2003</u>
Crédits à l'économie	993.7	1078.4	1266.8	1378.9
Crédits à l'Etat	677.4	569.7	578.7	420.8
Circulation fiduciaire	484.5	577.2	664.7	781.3
Dépôts à vue	563.7	661.3	751.6	849.7
Dépôts à terme	974.3	1235.0	1485.2	1723.9
Masse monétaire M2	2022.4	2473.5	2901.5	3354.9
Ratio de liquidité (%)	49.3	58.4	65.1	65.2

TAUX DE CHANGE.

(DA/US.\$)

	<u>1994</u>	<u>1995</u>	<u>1996</u>	<u>1997</u>	<u>1998</u>	<u>1999</u>
Taux de change moyen	35.09	47.68	54.77	57.73	58.74	66.64
Taux de change fin de période	42.89	52.18	56.19	58.41	60.35	69.32

	<u>2000</u>	<u>2001</u>	<u>2002</u>	<u>2003</u>
Taux de change moyen	75.29	77.26	79.69	77.37
Taux de change fin de période	75.34	77.82	79.72	72.61

VARIATION DES PRIX A LA CONSOMMATION.

(EN %)

	<u>1994</u>	<u>1995</u>	<u>1996</u>	<u>1997</u>	<u>1998</u>	<u>1999</u>
Inflation (moyenne annuelle)	29.05	29.78	18.69	5.73	4.95	2.64
Inflation (glissement sur 12 mois)	38.48	21.83	15.08	6.05	3.94	1.21

	<u>2000</u>	<u>2001</u>	<u>2002</u>	<u>2003</u>
Inflation (moyenne annuelle)	0.34	4.23	1.42	2.59
Inflation (glissement sur 12 mois)	0.12	7.56	-1.55	3.96

TAUX D'INTERETS.

(EN % PAR AN).

	<u>1994</u>	<u>1995</u>	<u>1996</u>	<u>1997</u>	<u>1998</u>	<u>1999</u>
Réesc compte (fin de période)	15.00	14.00	13.00	11.00	9.50	8.50
Réesc compte (moyen)	14.13	14.58	13.67	12.21	9.63	9.17
Base bancaire (fin de période) (*)	18.50	17.00	15.00	13.00	8.50	8.50
Base bancaire (moyen) (*)	17.63	18.00	16.33	14.00	9.25	8.50

	<u>2000</u>	<u>2001</u>	<u>2002</u>	<u>2003</u>
Réesc compte (fin de période)	6.00	6.00	5.50	4.50
Réesc compte (moyen)	7.13	6.00	5.50	4.92
Base bancaire (fin de période) (*)	8.50	8.00	6.50	6.50
Base bancaire (moyen) (*)	8.50	8.00	6.63	6.50

(*) Taux débiteurs.

LA DETTE EXTERIEURE

(EN MILLIONS DE US.\$)

	1992	1993	1994	1995	1996	1997	1998	1999	2000	2001
- Dette à MLT	25.886	25.024	28.850	31.317	33.230	31.060	30.262	28.140	25.088	22.311
- Dette à CT	792	700	636	256	421	162	212	175	173	260
- Total	26.678	25.724	29.486	31.573	33.641	31.222	30.474	28.315	25.261	22.571

	2002	2003
- Dette à MLT	22.540	23.203
- Dette à CT	102	150
- Total	22.642	23.353

SECTEUR REEL.

	UNITES	<u>1993</u>	<u>1994</u>	<u>1995</u>	<u>1996</u>	<u>1997</u>	<u>1998</u>
Le PIB	Mrds DA	1.165,0	1.487,4	2004,9	2.570,0	2.780,2	2.830,4
Le PIB	Mrds US.\$	49,9	42,4	42,0	46,9	48,2	48,2
Croissance du PIB	%	-2,1	-0,7	3,9	4,3	1,1	5,1
PIB par habitant	US.\$	1.856	1.542	1.498	1.643	1.658	1.633

	UNITES	<u>1999</u>	<u>2000</u>	<u>2001</u>	<u>2002</u>	<u>2003</u>
Le PIB	Mrds DA	3.248,2	4.098,8	4.235,6	4.455,4	5.149,4
Le PIB	Mrds US.\$	48,7	54,4	54,8	55,9	66,6
Croissance du PIB	%	3,2	2,4	2,1	4,1	6,8
PIB par habitant	US.\$	1.627	1.790	1.775	1.783	2.093

. () : _____

GRANGER

:(03)

	:			-1
Null Hypothesis:	Obs	F-Statistic	Probability	
IN does not Granger Cause S	30	0.64333	0.53559	
S does not Granger Cause IN		0.65371	0.53038	
	:			-2
Null Hypothesis:	Obs	F-Statistic	Probability	
YD does not Granger Cause S	30	24.2508	3.5 E-06	
S does not Granger Cause YD		18.0806	2.7 E-05	
	:			-3
Null Hypothesis:	Obs	F-Statistic	Probability	
Y does not Granger Cause MS	30	1.69721	0.20363	
MS does not Granger Cause Y		5.73526	0.00891	
	:			-4
Null Hypothesis:	Obs	F-Statistic	Probability	
IN does not Granger Cause MS	30	2.67223	0.08877	
MS does not Granger Cause IN		1.65102	0.21209	
	:			-5
Null Hypothesis:	Obs	F-Statistic	Probability	
R does not Granger Cause MS	30	2142.04	0.01528	
MS does not Granger Cause R		16.9236	0.16940	
	:			-6
Null Hypothesis:	Obs	F-Statistic	Probability	
E does not Granger Cause MS	30	154.906	0.05672	
MS does not Granger Cause E		0.35455	0.76492	

(TSP.EVIEWS.

)

:_____



‘

‘

؛

:

A.smith D.ricardo :

.

J.M.keyens (1933 – 1929)

.

M.friedman k.brummer :

‘

–

–

:

.

–

J.tobin. F.modigliani : ()

S.fisher : () ؛

:

()

‘

D.romer J.yellen

.

.



.

)

:

(

: "123 ' "

.

...

■

.

■

.

■

,

.

()

؛

:

.1

.2



.3

.4

:

-

-

"

-

-

"

:

(03)

)

-1

(

-2

,

-3

:

:

.1

.2



.3

⋮

.1

⋮

...

.3

⋮

⋮

-

-

-

-

⋮

1970

2001

⋮

:

.1

.2

: () .3

- **TSP.EVIEWS -MATLAB :**

... **SPSS**

.4

.5

⋮

، (04)



⋮

-
() -

) 2001 1970
(2006 2002)

⋮

()
,

1998 ، ، - - *

* Econométrie , Bendib Rachid , OPU , Alger, 2001

* Econométrie, Bourbonnie Regis, 5^{eme} edit, France , 2003

⋮

.
) -
(... -
-
.

-1- I

:

()

)

:

(

-1

- - :

(.... - -)

....

:

:(01)

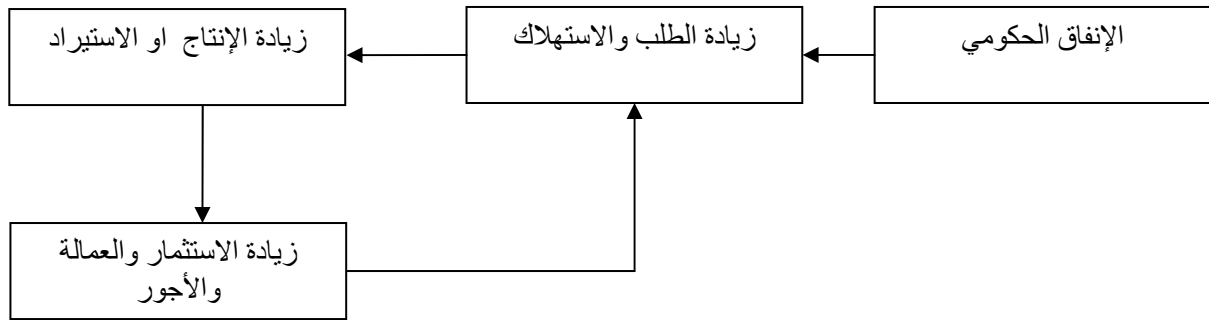

_____ :

...

:

()

(2)



(1) :

:

•

.

:

•

.

:

:

:

:

-

:

-

:

.

:

-

-2 :

:

الشكل (02) : مخطط دورة السياسة النقدية

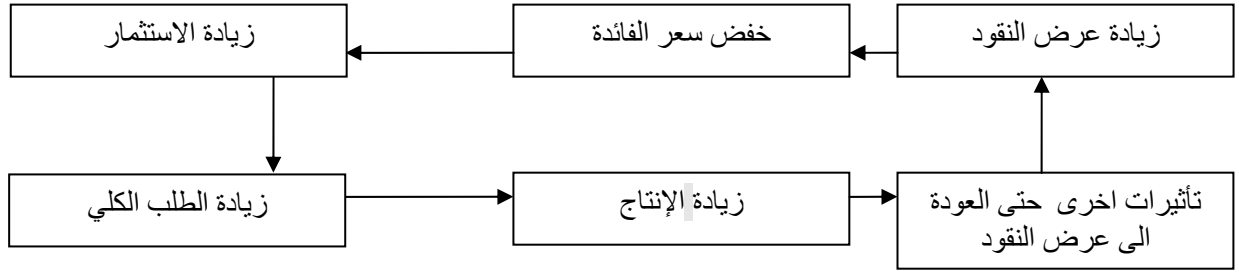

_____ :

_____ :

-3 _____ :

(1)

الشكل (03) : مخطط دورة تفاعل السياسة المالية والنقدية

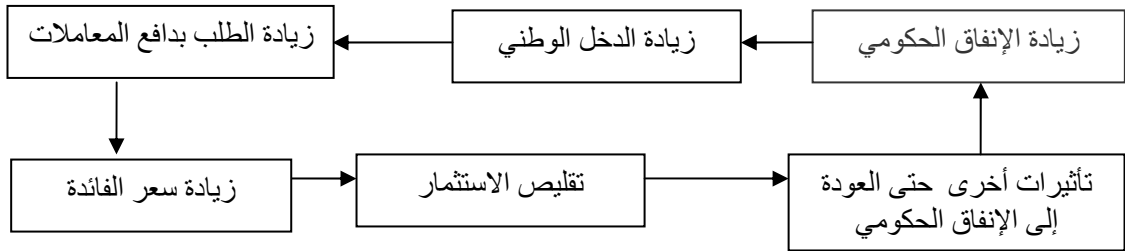

_____ :

، " " ، 19

- -



(1)

:

*

*

()

*

()

‘ - - - - :

‘

....

....

.

(2)

:

*

: 4

: (

. (... - -)

(... -)

.47 (1995

15 (.1997

:) _____ - (1)
:) _____ - (2)

(5)



(*
*
(...
*
(:
- - :
...- - :
(:
(:

(04) :

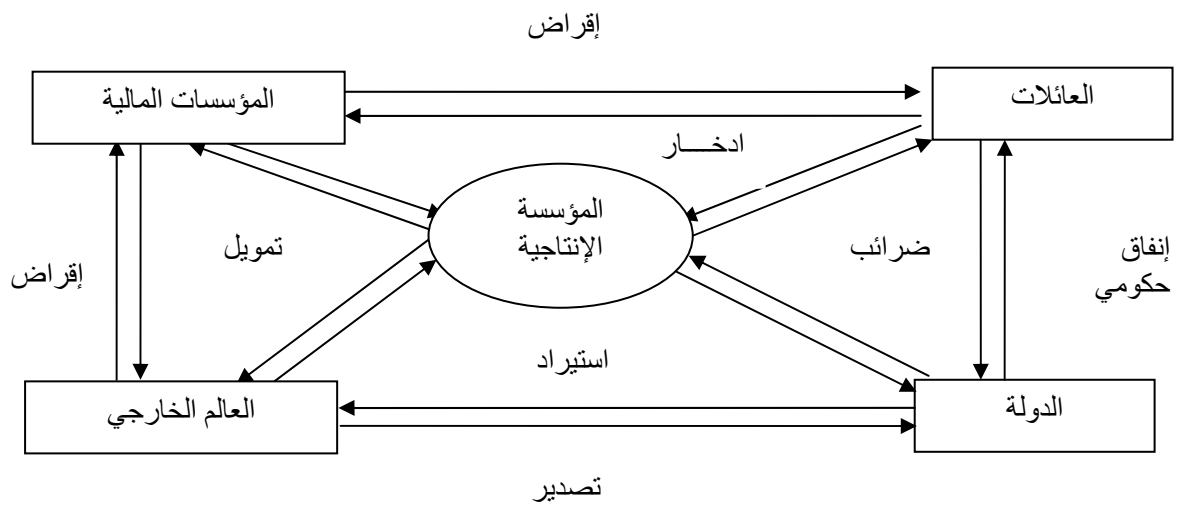

()

(6)



-2- 1

:

:

▪

C_0 ، I_0

:

▪

. ($C = C_0 > 0$) $y = 0$

:

▪

:

▪

:

▪

:

▪

(1) ...

()

:

:

()

-(

(02 01)

1998 ، ص ص 273- 281

(1) - عبد القادر محمد عبد القادر عطية ، الاقتصاد القياسي (بين النظرية والتطبيق) ،

(7)

$$Y_i = a + bD_i + \mu_i :$$

: D_i . : Y_i

. 01 : 1 = D_i

. 02 : 2 = D_i

(y_i) (02 01) b a

الشكل (05) : مخطط لمتغير كمي مع متغير نوعي بصفتين :

$$y_i = a + b \Rightarrow D_i = 1$$

$$y_i = a \Rightarrow D_i = 0$$

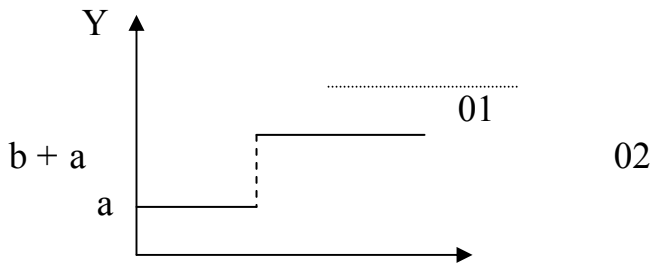

.279ص ، . - ' - ' : _____

: - (

: -1-

X_i * : y_i :

2 1 D_i *

$$Y_i = a_1 + a_2 D_i + b X_i + \mu_i :$$

:

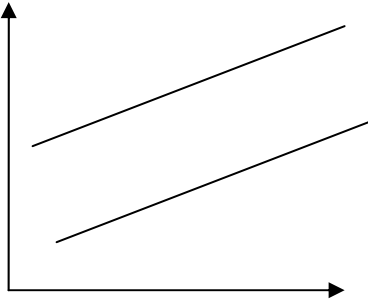

الشكل (05) :
مخطط متغير كمي مع
متغير نوعي بصفتين

$$01 \quad D_i = 1$$

$$02 \quad y_i = a_1 + bX_i \Rightarrow D_i = 0$$

ص 286 ،

$\alpha > 0$:

$$0 < \beta < 1 \quad C = \alpha + \beta y /$$

(Y)

(C)

(S)

(C)

(Y)

$$Y = C + S :$$

-3- I

(9)



,

:

- - - :

$$: \frac{-1-3- I}{-}$$

:

$$: -1-1-3- I$$

.

(Yd)

(C)

: -1

$$C=f(yd)$$

:

:

-

1949

" Duesenberry -

"

:

-

,

"

"

: Ypp

: Yc :

$$C=f(Yc Ypp)$$

1957

(M. Friedman)

:

-

yp

y



$y = y_p + y_t$: y_t
 : y_p
 : y_t
 y_p
 . y_{p-1}

:

$$C_t = C(1) + c(2) Y_{dt} + c(3) Y_{d,t-1}$$

() : $C_0 = C(1)$:
 $t-1$ t : $C(2)$ $C(3)$
 (S) : -2-I
 :

$$S_t = Y_t - C_t = Y_t - (C_0 + \zeta Y_{dt}) = -C_0 + (1 - \zeta) Y_{dt} = -C_0 + s Y_{dt}$$

$$S = f(y_d)$$

...

$$S = f(i) :$$

$$S = f(y_d, i) :$$

$$S_t = C(4) + C(5)Y_{dt} + C(6)IN_t :$$

$$: C(4)$$

$$: C(5) C(6)$$

$$: -2-1-3- I$$



$$I_t = C(7) - C(8) \cdot IN_t$$

$$: I_0 = C(7) :$$

$$: IN$$

$$: \Gamma = C(8)$$

$$: (\quad) \quad - 3 - 1 - 3 - I$$

:

$$: \quad - 1$$

:

- - - - -

G ' ...

' ... :

$$G = G_0$$

:

$$: G_0$$

$$: - 2$$

$$Y_d = Y - T$$

:

$$T_t = C(9) + C(10)Y_t \quad (0 < t < 1)$$

$$: T_0 = C(9)$$

$$: t = C(10)$$

(12)



:() - 4-1-3- I

: -1

X

$$X = X_0 :$$

(1)

: X₀

: -2

:

$$M_t = C(11) + C(12) \cdot Y_t$$

∴

$$: M_0 = C(11)$$

$$: m = C(12)$$

(YS) ()

(2) 1000

1000

:

$$YS = C + S + M + T$$

130 - (1)
68 - (2)

(13)

(C)

(yd)

(X)

(I)

:

$$Yd = C + I + X + G$$

:

$$Yd = YS \Rightarrow C + I + X + G = C + S + M + T$$

$$\Rightarrow X + G + I = S + M + T$$

:

-3-3- I

:

$$C_t = C(1) + c(2) Yd_t + c(3) yd_{t-1}$$

$$S_t = C(4) + C(5) Yd_t + C(6) i_t$$

$$I_t = C(7) - C(8) \cdot \dot{i}_t$$

$$T_t = C(9) + C(10) Y_t$$

$$M_t = C(11) + C(12) \cdot Y_t$$

$$X_t = X_{0t} \quad (\quad)$$

$$G_t = G_{0t} \quad (\quad)$$

$$I_t + X_t + G_t = S_t + M_t + T_t$$

()

: eit

()

-

-

(14)

$$C_t = C(1) + c(2) Yd_t + c(3) yd_{t-1} + \varepsilon_{1t}$$

$$S_t = C(4) + C(5) Yd_t + C(6) i_t + \varepsilon_{2t}$$

$$I_t = C(7) - C(8) \dot{I}_t + \varepsilon_{3t}$$

$$T_t = C(9) + C(10) Y_t + \varepsilon_{4t}$$

$$M_t = C(11) + C(12) Y_t + \varepsilon_{5t}$$

$$X_t = X_0 + \varepsilon_{6t}$$

$$G_t = G_0 + \varepsilon_{7t}$$

$$I_t + X_t + G_t = S_t + M_t + T_t$$

MCO

$$(y \quad x \quad x \quad y) \quad (\quad)$$

$$x = f(y) \quad y = f(x)$$

(1)

MCO

MCO

*

$$Y_i = a + bX_i + \varepsilon_i :$$

ε_i

$b \quad a$

MCO

$$E(\varepsilon_i) = 0 \quad .1$$

$$E(\varepsilon_i^2) = \sigma_\varepsilon^2 \quad .2$$

$$\text{COV}(\varepsilon_i, \varepsilon_j) = E(\varepsilon_i \cdot \varepsilon_j) = 0 \quad i \neq j \quad .3$$

$$(X_i \quad \varepsilon_i) \quad \text{COV}(x_i, \varepsilon_i) = 0 \quad .4$$

:

$$x = f(y) \quad y = f(x)$$

.(1)

Y X

GRANGER

Y

(back-feed -)

X

()

:

:

-1

$$y_t = \alpha_0 + \sum_{i=1}^{n1} \beta_i y_{t-i} + \sum_{i=1}^{n2} c_i x_{t-i} + \mu_{1t} \dots I$$

$$x_t = h_0 + \sum_{i=1}^{n3} k_i x_{t-i} + \sum_{i=1}^{n4} m_i y_{t-i} + \mu_{2t} \dots \Pi$$

$$E_i = \sum u_{it}^2 : ()$$

:

-2

:

$$y_t = \alpha_0 + \sum_{i=1}^{n1} \beta_i y_{t-i} + w_{it}$$

$$E_m = \sum w_{it}^2$$

:

-3

: F

$$\begin{cases} \sum c_i = 0 \forall i = 1 \dots n2 \\ \sum c_i \neq 0 \forall i = 1 \dots n2 \end{cases}$$

$$F_c = (E_m - E_i) / n2 / E_i / (n - k)$$

x

:n2 :

: n

:K

(1)- عبد القادر محمد عبد القادر عطية ، الاقتصاد القياسي - بين النظرية والتطبيق - (ط2 ؛ مصر : الدار الجامعية ، 1998) ؛ ص759



$$F_{(n2 \dots n-k)} = F_t$$

: -4

y: () () $F_t < F_c$:

GRANGER x

x y: () () $F_t > F_c$:

GRANGER

: Π -5

$$\begin{cases} \sum m_i = 0 \forall i = 1 \dots n4 \\ \sum m_i \neq 0 \forall i = 1 \dots n4 \end{cases}$$

:

$$\sum m_i = 0 \quad \sum c_i = 0 \quad y \quad x \quad x \quad y ($$

$$\sum m_i = 0 \quad \sum c_i = 0 \quad y \quad x \quad x \quad y ($$

$$\sum m_i = 0 \quad \sum c_i = 0 \quad y \quad x \quad x \quad y ($$

$$\sum m_i = 0 \quad \sum c_i = 0 \quad y \quad x \quad x \quad y ($$

MCO (y x)

$$X_i = \alpha + \beta Y_i + \varepsilon_{i2} \quad Y_i = a + bX_i + \varepsilon_{i1} :$$



()

()

.()

: - 1- II
:(1)

: -1 - 1- II

:

$$y_1 = \alpha_0 + \alpha_1 y_2 + \alpha_2 y_3 + \alpha_3 X_1 + \alpha_4 X_2 + \varepsilon_1 \dots(I)$$

$$y_2 = \beta_0 + \beta_1 y_1 + \beta_2 y_3 + \beta_3 X_1 + \beta_4 X_4 + \varepsilon_2 \dots(II)$$

$$y_3 = C_0 + C_1 y_1 + C_2 y_2 + C_3 X_1 + C_4 X_4 + \varepsilon_3 \dots(III)$$

:

- 1

y_3 y_2 y_1

. (III) (II) (I) y_1

() - 2

COV (ε_i , ε_j) = 0 MCO

:

(1) - عبد القادر محمد عبد القادر عطية ، مرجع سابق ، ص 502 - 517

$$B = \frac{\sum y_i x_i}{\sum x_i^2} \quad y_i = B x_{i1} + \varepsilon_i \quad :$$

$$B = \frac{\sum (B x_i + \varepsilon_i) x_i}{\sum x_i^2} \quad :$$

$$B = \left(\frac{\sum (B x_i^2) + \sum \varepsilon_i x_i}{\sum x_i^2} \right) \Rightarrow B = B + \frac{\sum \varepsilon_i x_i}{\sum x_i^2}$$

$$\beta \quad B \quad \sum X_i \varepsilon_i \neq 0 \quad : \quad \varepsilon_i \quad x_i$$

:

$$(\quad) \quad (II) \quad y_2 \quad y_1 \quad (I) \quad y_1 \quad \varepsilon_1$$

$$\text{COV}(\varepsilon_1, y_2) \neq 0 : \quad y_2 \quad (\quad) \quad \varepsilon_1 : \quad y_2 \leftarrow y_1 \leftarrow \varepsilon_1$$

:

-2 - 1 - II

:

$$y_1 = \alpha_0 + \alpha_1 X_1 + \alpha_2 X_2 + \varepsilon_1 \dots (I)$$

$$y_2 = \beta_0 + \beta_1 y_1 + \beta_2 X_1 + \beta_3 X_2 + \varepsilon_2 \dots (II)$$

$$y_3 = C_0 + C_1 y_1 + C_2 y_2 + C_3 X_1 + C_4 X_2 + \varepsilon_3 \dots (III)$$

$$(II) \quad y_1 \quad y_3 \quad y_2 \quad y_1 \quad 3$$

$$X_1 \quad y_3 \quad (III) \quad y_2 \quad y_1 \quad y_2$$

X₂

:

$$y_3 \quad y_2 \quad y_1 \quad y_2 \quad y_1 \quad -(1)$$

$$. (\quad)$$

$$y_2 \quad \varepsilon_2 \quad -(2)$$

$$. \text{MCO} \quad \text{COV}(X_1, \varepsilon_1) = 0 \quad : \quad y_1$$

$$\text{MCO} \quad \varepsilon_3, \varepsilon_2, \varepsilon_1 \quad -(3)$$

:

$$y_1 = \alpha_0 + \alpha_1 y_2 + \alpha_2 X_1 + \alpha_3 X_2 + \varepsilon_1 \dots (I)$$

$$y_2 = \beta_0 + \beta_1 y_1 + \beta_2 X_1 + \beta_3 X_2 + \varepsilon_2 \dots (II)$$

$$y_3 = C_0 + C_1 y_1 + C_2 y_2 + C_3 X_1 + C_4 X_2 + \varepsilon_3 \dots (III)$$

y_2 y_1

(II) (I)

y_2 y_1

y_3

(III)

MCO

y_2 y_1

y_3

: (SURE)

:

$$y_1 = \alpha_0 + \alpha_1 x_1 + \alpha_2 X_2 + \varepsilon_1 \dots (I)$$

$$y_2 = \beta_0 + \beta_1 X_3 + \beta_2 X_4 + \varepsilon_2 \dots (II)$$

$$y_3 = C_0 + C_1 X_5 + C_2 X_6 + \varepsilon_3 \dots (III)$$

:

y_3 y_2 y_1

.1

$$y_1 = f(x_1, x_2) \quad y_2 = f(x_3, x_4) \quad :$$

$$y_3 = f(x_5, x_6)$$

$\varepsilon_3, \varepsilon_2, \varepsilon_1$

.2

MCO

$$E(\varepsilon_1, \varepsilon_3) \neq 0$$

$$E(\varepsilon_1, \varepsilon_2) \neq 0$$

$$E(\varepsilon_2, \varepsilon_3) \neq 0$$

:

$\varepsilon_3, \varepsilon_2, \varepsilon_1$

.3



MCO
 (Zelliner - Atkin) - (GLS - MCG)

: - 2- II

:

.1 (feed-back)

GRANGER
 .2

.
 -3

C_t C_t ε₁

S_t (y_d_t = C_t + S_t) C_t

. ε₂

‘ MCO
 (COV ε_j) ≠ 0 (x_i:)

)

(Probleme d' identification

:

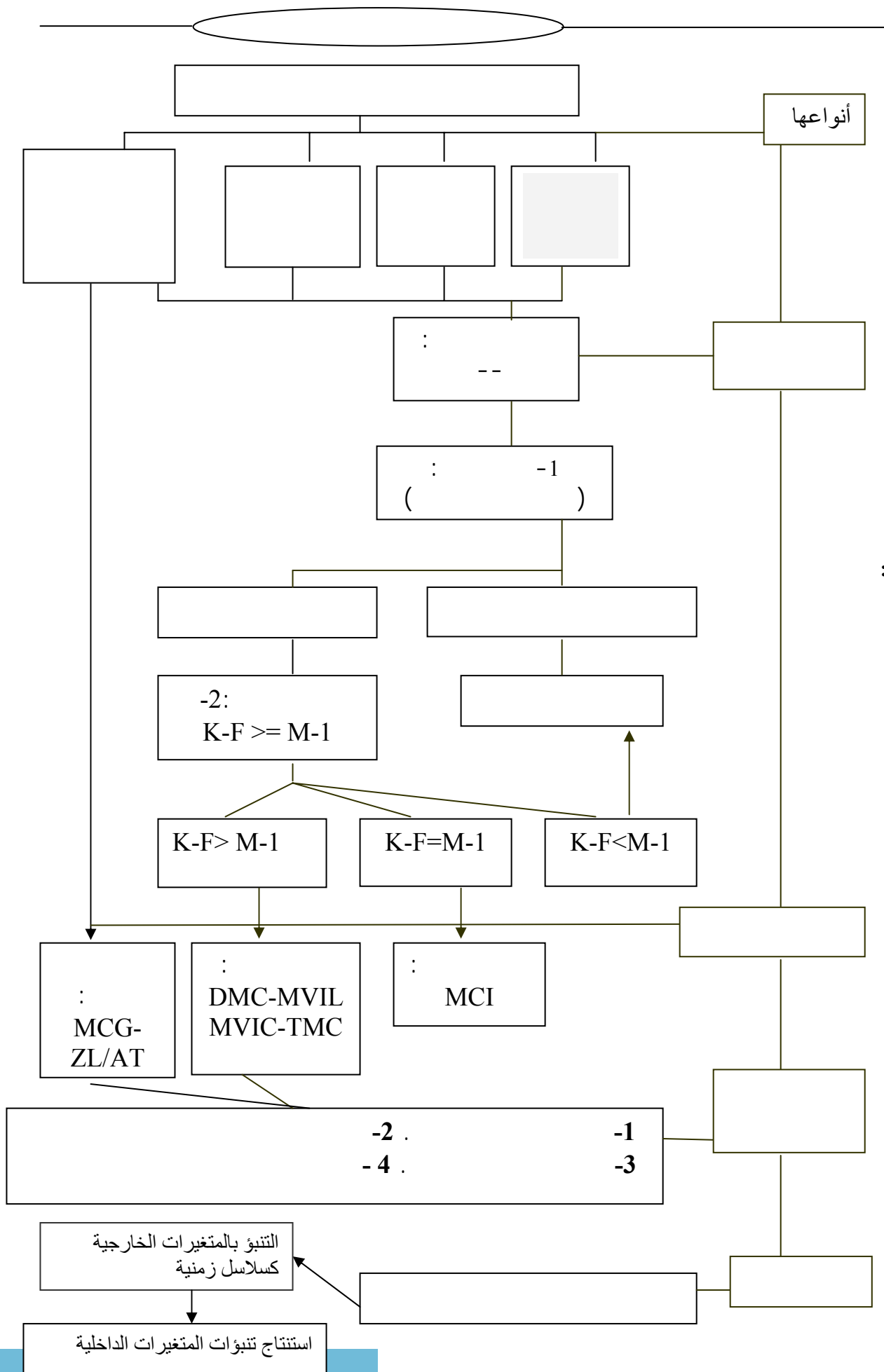

الشكل (07) :



GRANGER

(I) $Q_d = \alpha + \beta P + \varepsilon_1$
 (II) $Q_0 = \alpha_1 + \beta_1 P + \varepsilon_2$
 (III) $Q_d = Q_0$
 (IV) $Q_d = \alpha + \beta P + \varepsilon_1$
 (V) $Q_0 = \alpha_1 + \beta_1 P + \varepsilon_2$
 (VI) $Q_d = Q_0$

: (L' identification)
 -1-3- II
 -1-1-3- II

$Q_d = \alpha + \beta P + \varepsilon_1$:
 $Q_0 = \alpha_1 + \beta_1 P + \varepsilon_2$:
 $Q_d = Q_0$:

: P : Q_0 : Q_d :
 (\leq :) :
 . P Q_0 Q_d : 3 3 :
 : :
 . () ($Q_d = Q_0$)



(P)

(Q)

MCO

(1) ($Q = Q_0 = Q_d$:)

Q

MCO

:

03

(2)

:

:(08)

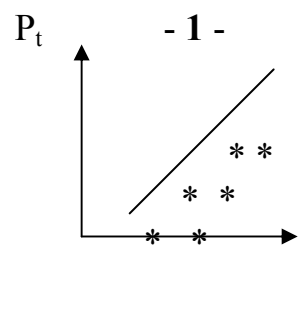
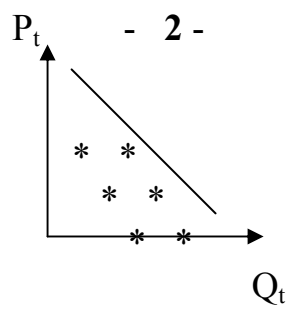
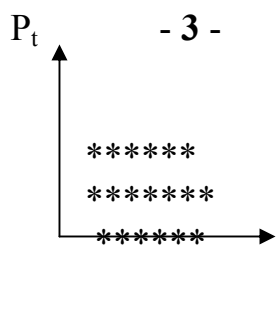

276 ، . ' - ' - : (1) :

(- :) : (2)

(- :) : (3)

β_1

β

(1) - عبد القادر محمد عبد القادر عطية ، مرجع سابق ، ص 521

(2) - β أو β_1 .



:
: () (P)

$$Q_d = \alpha + \beta P + \varepsilon_1$$

$$Q_0 = \alpha_1 + \beta_1 P + \sigma_1 C + \varepsilon_2$$

$$Q_d = Q_0$$

,

: -2-1 - 3- II

:

(Rang) -(

(Order) -(

: (Rang) -(

m

(m-1) .(m-1)

:

.

-1

-2

-3

(m-1) .(m-1)

-4

-(: (Order)

()

()

: $K - F \geq m - 1$:

() : K

() : F

: K - F

= : m

: (03)

: (1) -3-1 -3 - II

: (sur- identifiée) *

() $K - F > m - 1$

()

: (juste - identifiée) *

$K - F = m - 1$

()

: (sous- identifiée) *

$K - F < m - 1$

()

_____ :

)

(1) - عيد القادر محمد عبد القادر عطية ، مرجع سابق ، ص 531 - 536 ؛

دومنيك سالفادور ، الاحصاء و الاقتصاد القياسي (مصر : دار ماكجروهيل للنشر ، 1982) ، ص 243



(
: (I' estimation) -2- 3- II

()

: (09)

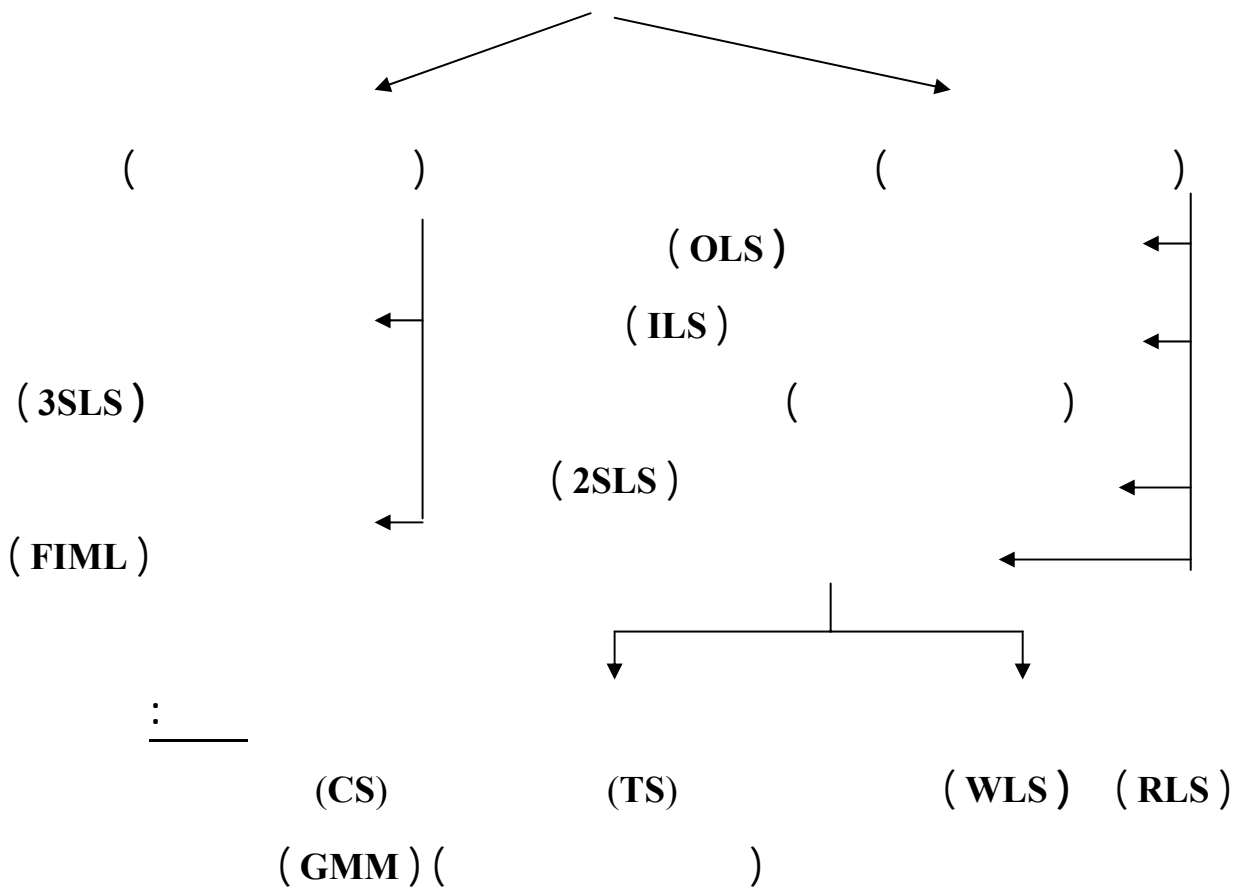

:() -1-2- 3- II

:(OLS - MCO) -(

OLS

(1)

$$Y_t = \beta_0 + \beta_1 X_{1t} + \beta_2 X_{2t} + \dots + \beta_k X_{kt} + \varepsilon_t \quad t = 1$$

$$\beta = (\beta_0 \beta_k) \beta = (X'X)^{-1} X'y : \dots \beta_1 \quad \text{MCO}$$

:(ILS - MCI) : -(

()

(f. réduite) () (f. Structurelle) -(1

OLS -(2

MCO -(3

:(2

$$Q_t = y_1 + y_2 P_t + y_3 y_t + \varepsilon_{1t}$$

$$Q_t = \beta_1 + \beta_2 P_t + \beta_3 W_t + \varepsilon_{2t}$$

W_t y_t P_t Q_t :

()

m = 2 K = 4 :

$$K - F = m - 1 \Leftarrow F = 3 / K - F = 4 - 3 = 1 :$$

$$m - 1 = 2 - 1 = 1$$

$$K - F = m - 1 \Leftarrow F = 3 / K - F = 4 - 3 = 1 :$$

$$m - 1 = 2 - 1 = 1$$

:(1

$$P_t = \gamma_1 - \beta_1 / (\beta_2 - \gamma_2 + \gamma_3 / \beta_2 - \gamma_2) y_t - \beta_3 w_t / (\beta_2 - \gamma_2) + \mu_{1t} :$$

$$Q_t = \gamma_1 \beta_2 - \gamma_2 \beta_1 / (\beta_2 - \gamma_2) + (\gamma_3 \beta_2 / \beta_2 - \gamma_2) y_t - (\gamma_2 \beta_3 / \beta_2 \gamma_2) w_t + \mu_{2t}$$

$$\mu_{1t} = \varepsilon_{1t} - \varepsilon_{2t} / \beta_2 - \gamma_2 :$$

$$\mu_{2t} = \beta_2 \varepsilon_{1t} - y_2 \mu_{2t} / \beta_2 - \gamma_2$$

$$P_t = \Pi_{11} + \Pi_{12} y_t + \Pi_{13} w_t + \mu_{1t} \quad :$$

$$. Q_t = \Pi_{21} + \Pi_{22} y_t + \Pi_{23} w_t + \mu_{2t}$$

$$: \text{MCØ} \quad \text{-(2)}$$

$$P_t = \Pi_{11} + \Pi_{12} y_t + \Pi_{13} w_t \quad :$$

$$Q_t = \Pi_{21} + \Pi_{22} y_t + \Pi_{23} w_t$$

$$. \text{MCØ} \quad \Pi_{ij} \quad \Pi_{ij} :$$

:

$$\Pi_{13} = -\beta_3 / \beta_2 - \gamma_2, \quad \Pi_{12} = \gamma_3 / \beta_2 - \gamma_2, \quad \Pi_{11} = \gamma_1 - \beta_1 / \beta_2 - \gamma_2$$

$$\Pi_{23} = -\gamma_2 \beta_3 / \beta_2 - \gamma_2, \quad \Pi_{22} = \gamma_3 \beta_2 / \beta_2 - \gamma_2, \quad \Pi_{21} = \gamma_1 \beta_2 - \gamma_2 \beta_1 / \beta_2 - \gamma_2$$

$$: \quad \text{-(3)}$$

$$: \quad 6 \quad 6$$

$$1) \gamma_1 = \Pi_{11} (\Pi_{21} / \Pi_{11} - \Pi_{23} / \Pi_{13})$$

$$2) \beta_1 = \Pi_{11} (\Pi_{21} / \Pi_{11} - \Pi_{22} / \Pi_{12})$$

$$3) \gamma_2 = \Pi_{23} / \Pi_{13}$$

$$4) \beta_2 = \Pi_{22} / \Pi_{12}$$

$$5) \gamma_3 = \Pi_{12} (\Pi_{22} / \Pi_{12} - \Pi_{23} / \Pi_{13})$$

$$6) \beta_3 = \Pi_{13} (\Pi_{23} / \Pi_{13} - \Pi_{22} / \Pi_{12})$$

$$. (i = 1, 2, 3) \beta_i \quad \gamma_i \quad \beta_i \quad \gamma_i$$

. MCO

MCI

:

:(¹) (2SLS - DMC)

-(

()

(variable instrumentale)

:

()



-(1)

.

-(2)

:

$$(1) \dots y_i = y_i \beta_i + X_i \sigma_i + \varepsilon_i : \quad \zeta^{eme} \quad :$$

$$y_i = [y_i \ X_i][\beta_i \ \sigma_i]' + \varepsilon_i \quad :$$

$$y_i = X_i \Pi_i + v_i \quad : \quad \Pi_i \quad :$$

$$\Pi_i = (X'X)^{-1} X' y_i \quad : \quad \text{MCO}$$

$$y_i = X_i (X'X)^{-1} X' y_i \quad :$$

$$. \ \varepsilon_i \quad y_i :$$

$$. \text{MCO} \quad (1) \quad :$$

$$y_i = [y_i \ X_i][\beta_i \ \sigma_i]' + \varepsilon_i \quad : \quad :$$

$$[\beta_i \ \sigma_i]' = \{ [y_i \ X_i]' [y_i \ X_i] \}^{-1} [y_i \ X_i]' y_i \quad :$$

$$\begin{bmatrix} y_i y_i & y_i x_i \\ x_i y_i & x_i x_i \end{bmatrix} \begin{bmatrix} Y_i y_i \\ x_i y_i \end{bmatrix}$$

$$[\beta_i \ \sigma_i]' = \begin{bmatrix} Y_i x (xx)^{-1} xy_i & Y_i x_i \\ Xy_i & x_i x_i \end{bmatrix}^{-1} \begin{bmatrix} Y_i x (xx)^{-1} xy_i \\ x_i y_i \end{bmatrix}$$

$$\sigma_i \ \beta_i$$

⋮

2SLS

-(1)

()



() 2SLS -(2)
) ()

(1) (ILS

: (MCR - RLS) -(

$$y = \alpha + \beta_1 x_1 + \beta_2 x_2 + \mu \dots \dots (I)$$

$$\beta_1 = k : \beta_1$$

: (I)

$$Y - kx_1 = \alpha + \beta_2 x_2 + \mu$$

$$y^* = y - kx_1 \quad / \quad y^* = \alpha^* + \beta_2^* x_2 + \mu$$

MCO :

:() -2-2-3- II

(3 SLS - TMC)

:(TMC) -A

: (MCG - GLS)

: G ϵ^{eme} :

$$Y_i = y_i \beta_i + x_i \gamma_i + \mu_i \dots \dots (I)$$

: Y_i :

: y_i

(1)-RACHID BENDIB , OP.CIT , P 70

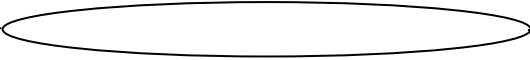

$$Z_i = (y_i \quad x_i) \quad \alpha_i = (\beta_i \quad \gamma_i)' \quad Y_i = Z_i \alpha_i + \mu_i \quad (I)$$

$$: \quad (\quad : X') X' \quad (I)$$

$$X' Y_i = X' Z_i \alpha_i + X' \mu_i \dots (II)$$

$$X' \mu_i \quad (\quad) \quad X' Z_i \quad X' Y_i$$

$$: \quad (II) \quad MCG$$

$$E(X' \mu_i \mu_i' X) = \sigma_i (X' X) \quad \alpha_i^{\wedge} = (Z_i' X (X' X)^{-1} X' Z_i)^{-1} Z_i' X (X' X)^{-1} X' Y_i$$

$$: \quad \hat{\mu}^{eme} \quad DMC \quad \alpha_i^{\wedge}$$

$$X' Y_1 = X' Z_1 \alpha_1 + X' \mu_1$$

$$X' Y_2 = X' Z_2 \alpha_2 + X' \mu_2$$

$$: \quad : \quad :$$

$$X' Y_G = X' Z_G \alpha_G + X' \mu_G$$

$$\begin{bmatrix} x'y_1 \\ x'y_2 \\ \vdots \\ x'y_G \end{bmatrix} = \begin{bmatrix} x'z_1 & 0 & : & 0 \\ 0 & x'z_2 & : & : \\ \vdots & \vdots & : & 0 \\ 0 & . & 0 & x'z_G \end{bmatrix} \begin{bmatrix} \alpha_1 \\ \alpha_2 \\ \vdots \\ \alpha_G \end{bmatrix} + \begin{bmatrix} x'\mu_1 \\ x'\mu_2 \\ \vdots \\ x'\mu_G \end{bmatrix}$$

$$\Rightarrow Q = W * D + R$$

:

$$\Omega = \begin{bmatrix} \sigma_{11}x'x & \sigma_{11}x'x & \dots & \sigma_Gx'x \\ \sigma_2x'x & \sigma_{22}x'x & \dots & \sigma_{2G}x'x \\ \dots & \dots & \dots & \dots \\ \sigma_Gx'x & \dots & \dots & \sigma_{GG}x'x \end{bmatrix}$$

$$\Rightarrow \Omega = \Sigma \otimes X'X / \Sigma = \begin{bmatrix} \sigma_{11} & \sigma_2 & \dots & \sigma_g \\ \sigma_{12} & \sigma_{11} & \dots & \sigma_{11} \\ \dots & \dots & \dots & \dots \\ \sigma_{G1} & \sigma_{11} & \dots & \sigma_{GG} \end{bmatrix}$$

$$\Omega^{-1} = \Sigma^{-1} \otimes (X'X)^{-1} : \quad \Omega^{-1}$$

: (1) (GLS - MCG)

$$D^{\wedge} = (w/\Omega^{-1}w)^{-1}w/\Omega^{-1}Q \quad / \quad Q = wD + R$$

. (TMC)

$$\Omega \quad \Sigma \quad D \quad :$$

: DMC

$$. (\mu_i) \quad \text{DMC} \quad - (1)$$

$$S_{ij} = \mu_i^{\wedge} \mu_j^{\wedge} / n - g_i - k_i : \quad \Sigma \quad \sigma_{ij} \quad - (2)$$

. : k_i , : n :

: (FIML- MVIC) -B

TMC MVIC

. ()

$$\mu_t \dots N(0, \Sigma) \quad \beta Y_t = \Gamma X_t + \mu_t :$$

:

(1) -RACHID BEN DIB , OP.CIT , p156.

$$\mu_t = \begin{bmatrix} \mu_{1t} \\ \mu_{1t} \\ \vdots \\ \mu_{1t} \end{bmatrix} \quad xt = \begin{bmatrix} x_{1t} \\ x_{1t} \\ \vdots \\ x_{1t} \end{bmatrix} \quad yt = \begin{bmatrix} y_{1t} \\ y_{1t} \\ \vdots \\ y_{1t} \end{bmatrix}$$

:

$$\Gamma = \begin{bmatrix} \gamma_{11} & \gamma_{12} & \dots & \gamma_{1k} \\ \gamma_{21} & \gamma_{22} & \dots & \gamma_{2k} \\ \dots & \dots & \dots & \dots \\ \gamma_{G1} & \dots & \dots & \gamma_{GK} \end{bmatrix} \quad \mathbf{B} = \begin{bmatrix} \beta_{11} & \beta_{12} & \dots & \beta_{1G} \\ \beta_{21} & \beta_{22} & \dots & \beta_{2G} \\ \dots & \dots & \dots & \dots \\ \beta_{G1} & \dots & \dots & \beta_{GG} \end{bmatrix}$$

: μ_t G

$$f(\mu_t) = (2\Pi)^{-G/2} |\Sigma|^{-1/2} \text{EXP} \left[(-1/2) \mu \Sigma_t^{-1} \mu_t \right]$$

: () μ_t

: $\mu_n \dots \mu_2 \mu_1$: n

$$f(\mu_1 \cdot \mu_2 \dots \mu_n) = \Pi f(\mu_t) = (2\Pi)^{-nG/2} |\Sigma|^{-n/2} \text{EXP} \left[(-1/2) \mu \Sigma_t^{-1} \Sigma^{-1} \mu_t \right]$$

:

$$f(y_t) / \partial \mu_t = f(y_t) / \partial y_t \Rightarrow f(\mu_t) \partial \mu_t / \partial y_t = f(\mu_u) |\det \mathbf{B}|$$

: $y_n \dots y_2 \cdot y_1$: n

$$f(y_1 \cdot y_2 \dots y_n) = \Pi f(y_t) = \Pi f(\mu_t) = \Pi f(y_t) = \Pi f(\mu_u) |\det \mathbf{B}|$$

$$\Rightarrow L = (2\Pi)^{-NG/2} |\det \mathbf{B}|^n |\Sigma|^{-n/2} \exp(-1/2) \Sigma (\mathbf{B} y_t + \Gamma x_t)' \Sigma^{-1} (\mathbf{B} y_t + \Gamma x_t)$$

$$\mu_t = \mathbf{B} y_t + \Gamma x_t :$$

MVIC $\mathbf{L} \quad \Gamma \quad \mathbf{B} :$

L

-C (1) (GMM -MGM)

(variable instrumental)

- (times series)

- (cross sections)

-3 - 3- II : (choix)

()

:

-(:

ILS 2SLS

ILS OLS

. ... GMM-3SLS -2SLS :

-(:

OLS -

OLS

LMIL 2SLS -

FMIL 3SLS -

. LMIL 2SLS

FMIL 3SLS

(1)- لمزيد من الاطلاع لاحظ الصفحة المساعدة لبرنامج TSP. EVIEWS وذلك بالبحث على كلمة GMM حيث نحصل على تعريف الطريقة .

				:	-(
.				(1958) Basman R.L	
b		b^{\wedge}	$b^{\wedge}-b$:	*
	. OLS	3SLS	2SLS	LMIL FMIL	
3SLS	2SLS	FMIL	OLS		*
				LMIL	
			:		-(
	OLS	ILS	LMIL		*
FMIL			(multi colinéarité)		*
			. OLS	2SLS LMIL	
(auto corrélation des erreurs)					*
	. LMIL	ILS	2SLS	OLS	
		:		2SLS	
		.			-
		.	()		-
		.	(1)		-
		:			
			<u>: (La prévision)</u>	<u>-4 - 3- II</u>	
:					
		.	(multi colinéarité)		-1
	.		(auto corrélation des erreurs)		-2

(1)- RACHID BENDIB , OP.CIT , p166.



. (hétéroscédasticité)

-3

.

() (punctual)

.

(intervalle)

t+1

,

)

.(

:

-1-4 -3- II

()

:

-a

(1) ()

.

- :

.

-

(Pics)

: (2)

-b

:

: (TREND-tendance)

-1

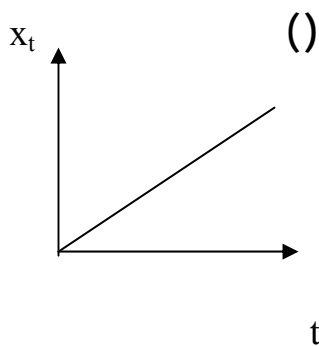

T_t

: t :

.(:)

: X_t

(1) - Hocine Hamdani , statistique descriptive , (1^{er} ed Alger : opu 1999), p230.

() - () - () - () : - (2)
() - ()



: -2

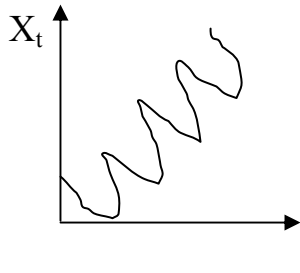

()

S_t

- :

-

: -3

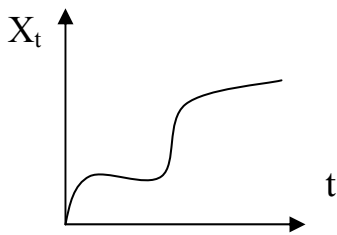

()

- :

-

C_t

:

: -4

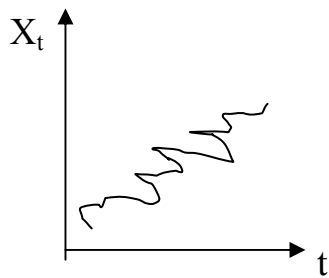

()

... ..

ϵ_t

()

:

-c

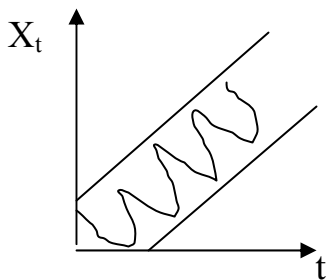

()

:

: -1

$$X_t = T_t + S_t + C_t + \epsilon_t$$

.()

$$X_t = T_t + S_t + C_t + \epsilon_t$$



() : : -2

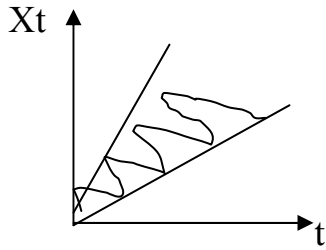

$$X_t = T_t \times S_t \times C_t \times \varepsilon_t$$

: ()
()

- :

:

$$\sigma_i = a + b\bar{y}_i / i = 1, \dots, m \quad : \quad -(1)$$

$$\forall j = 1, \dots, p \bar{y}_i = 1/p \sum_{j=1}^p y_{ij}, \sigma_i = \sqrt{1/p \sum (y_{ij} - \bar{y}_i)^2} \quad m :$$

$$\hat{b} = \sum (\sigma_i \bar{y}_i - m\bar{\bar{y}}) / \sum (y_i^2 - m\bar{\bar{y}}^2) : \quad (\text{MCO})\text{OLS}$$

: 03 : -(2)

$$0.05 < \hat{b} < 0.1 :$$

$$\hat{b} < 0.05$$

$$\hat{b} > 0.1$$

: -d

: ()

BOX - : (ARIMA) -1

JENKINS

(VAR) -2

... : -3

Box-jenkins

: (1) ()

- : (11)

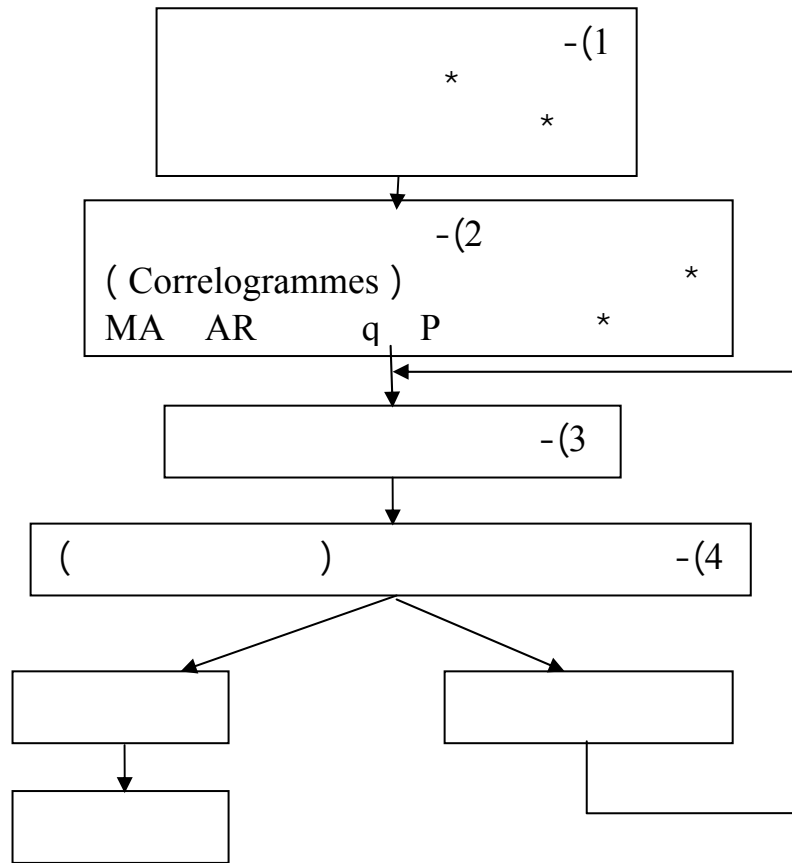

économétrie : (R. Bourbonnais, P 121) :

: () -1

: ()

$E(x_t) = \mu$: - (1)

$V (X_t) = E(X_t - \mu)^2 = \sigma^2$: - (2)

() - (3)

$COV (x_t, x_{t+k}) = E[(X_t - \mu) . (X_{t+k} - \mu)] = \gamma_K$:

(1) - Bourbonnais REGIS, économétrie (5^{ème} ed ; France : Dunod 2003) , p121



: -1-1

: *

: k

$$\begin{aligned} \rho_K &= COV(X_t, X_{t-k}) / \sqrt{V(X_t)} \sqrt{V(X_{t-k})} \\ &= E(X_t - \mu)(X_{t-k} - \mu) / \sqrt{E(X_t - \mu)^2} \sqrt{E(X_{t-k} - \mu)^2} \\ &= \gamma_k / \gamma_0 \end{aligned}$$

: $\gamma_0 \gamma_K$

$$\hat{\rho}_k = \hat{\gamma}_k / \hat{\gamma}_0$$

$$\hat{\gamma}_k = (1/T) \sum (X_t - \bar{X})(X_{t-k} - \bar{X}), \hat{\gamma}_0 = (1/T) \sum (X_t - \bar{X})^2, \bar{Y} = (1/T) \sum Y_t$$

T :

$\rho_k = 0$

1 1- ρ_k

) % 5

(: n) 1/n . (0)

$$IC = \{\pm 1.96\sqrt{1/n}\} : (n \geq 30)$$

$$\begin{cases} H_0 : \hat{\rho}_K = 0 \\ H_1 : \exists \hat{\rho}_K \neq 0 \end{cases} :$$

$\forall K = 1 \dots m$

()

H_0 IC $\hat{\rho}_K$:

()

H_1 IC $\hat{\rho}_K$:

: Q

: **Box- Pierce**

:

$$\begin{cases} H_0 : \hat{\rho}_1 = \hat{\rho}_2 = \dots = \hat{\rho}_m = 0 \\ H_1 : \exists \hat{\rho}_k \neq 0 \\ \forall k = 1 \dots m \\ Q = n \sum \rho^2_k \end{cases}$$

() H₀ $\chi_m^2 < Q$:
 (LB) Ljung - Box (Q) :
 : () -2-1

(1) ()

BUYS-BALLOT

" " : - (1)
 (T_t)

$$T_t = a_0 + a_1 t + \varepsilon_t$$

;(2)

$$P = 4 ()$$

(2) - Michel Tiraza et R. Bourbonnais, économétrie des séries temporelles (1^{er} ed , France : Dunod 1997) , P 96

: (12)

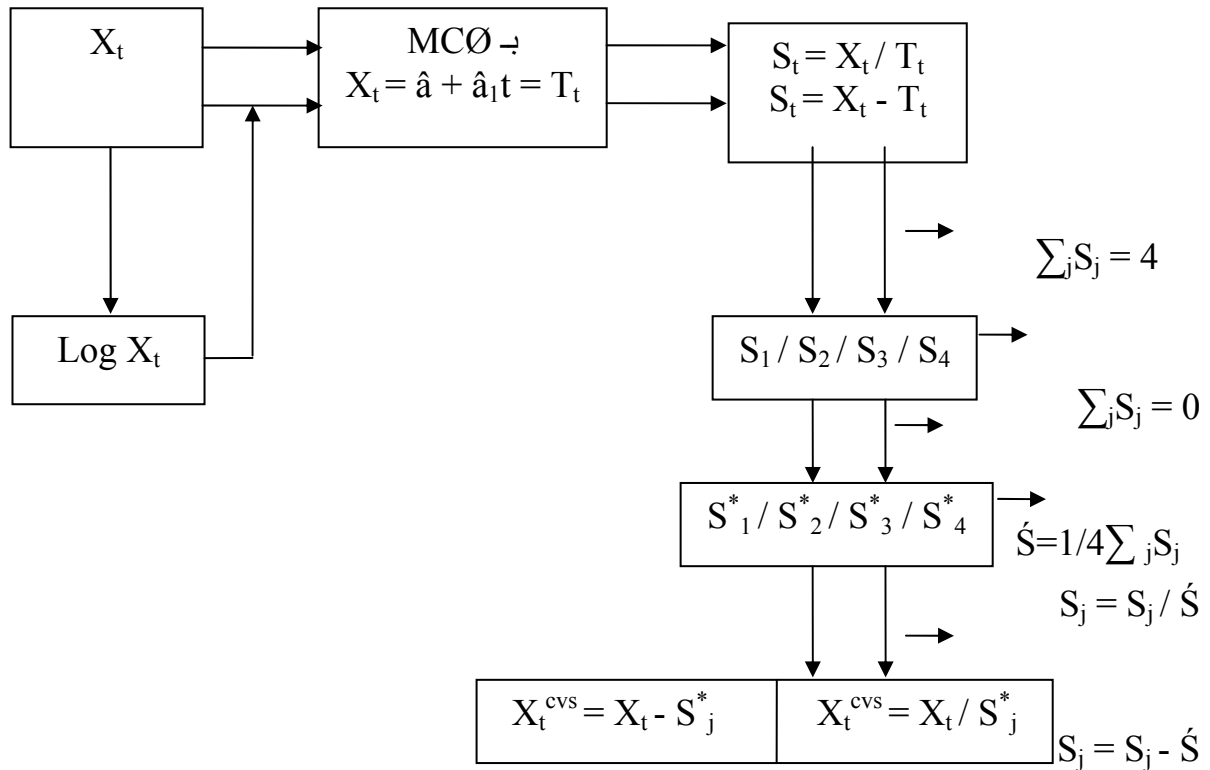

économétrie des séries temporelles (M. tiraza et R. Bourbonnais , p 96) : _____

: (filtrage) - (2)

-1-2

(S_t) (T_t)

$$X_t = T_t + \varepsilon_t \quad :$$

$$E(\varepsilon'_t \cdot \varepsilon_t) = \sigma^2 \quad E(\varepsilon_t) = 0 :$$

$$V(X_t) = \sigma^2 \quad E(X_t) = T_t \quad :$$

: \bar{Y}_y

$$E(\bar{Y}_y)^2 = E\left(\left(\frac{1}{n}\right) \sum y_{t-r}\right)^2 = 1/n^2 (n\sigma^2) = \sigma^2 / n$$

-2-2

$$\Delta^P Y_t = Y_t - Y_{t-P}$$

$$= (1 - L^P) Y_t$$

(P = 12)

(P = 4)

P = 1

$$\Delta Y_t = Y_t - Y_{t-P} \quad (t) \quad -(1)$$

$$\Delta Y_{t+1} = Y_{t+1} - Y_{t-P+1} \quad : \quad (t+1)$$

$$Y_{t+1} = \Delta Y_{t+1} + Y_{t-P+1} \quad : \quad y_{t+1} \quad -(2)$$

-(

() :

()

: -1

$$T_t = \alpha_0 + \alpha_1 t / X_t = T_t + \varepsilon_t = \alpha_0 + \alpha_1 t + \varepsilon_t$$

$$\varepsilon_t = X_t - (\alpha_0 + \alpha_1 t) :$$

$$T_t = \alpha_0 + \alpha_1 t + \alpha_2 t^2 / X_t = \alpha_0 + \alpha_1 t + \alpha_2 t^2 + \varepsilon_t$$



: (ARIMA) -(4)
 () ARMA

. ARIMA (P , d , q)

d :
 (1)

:

X_t

d = 1 $W_t = X_t - X_{t-1}$

ARIMA (P,1,q)

W_t

d = 2 : $Z_t = W_t - W_{t-1}$:

... ARIMA (P,2,q)

Z_t

:

-(5)

()

SARIMA (P, d, q)^S(P, D, Q)

. SARMA (P,Q)

S

Q P :

. D

P

: D

SAR (P)

:

SARMA (Q P) :

SMA (Q)

: -

: (identification) -2- 2 - 4 -3 - II

)

: P D Q q d P (

. (AC) -

. (PAC) -

ARMA (P , q) MA (q) . AR (P) (1)

:

ARIMA : (01)

PAC	AC	
(décroissante exponentielle)	q	MA(q)
p	(décroissante exponentielle)	AR(p)
		ARMA(p, q)

(89 ,) : _____

) 12 () 4 (pics) (2

(

1= D :

) 12 24 () 8 4 (pics) (3

2=D : (

: -1- 2 - 4 -3 - II



:

- : (13)

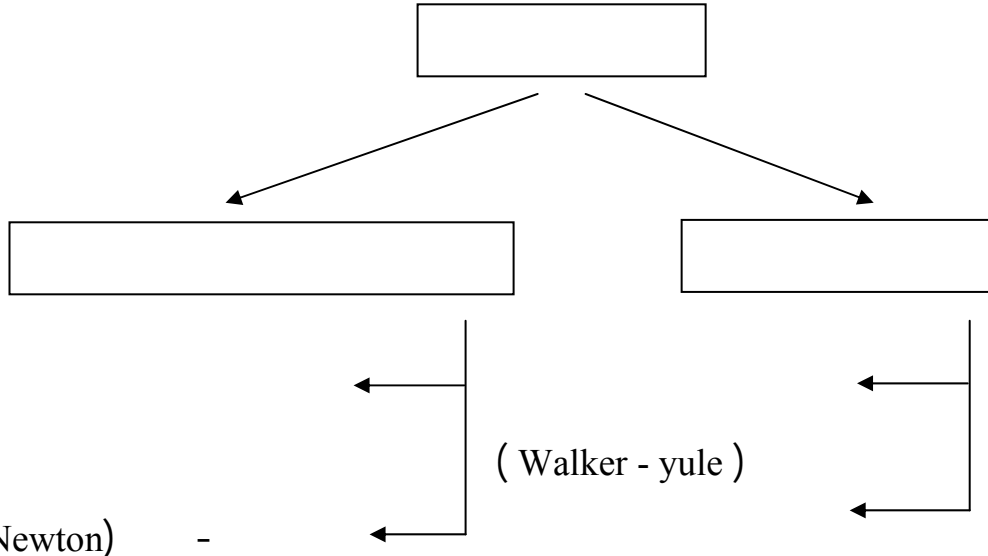

⋮

: AR (P) -1-2

: a_p, ... a₂, a₁ P

: -1-1-2

: P

$$Y_t = \theta_1 Y_{t-1} + \theta_2 Y_{t-2} + \dots + \theta_P Y_{t-P} + \varepsilon_t \dots (I)$$

$$Y_{t-P} \quad Y_{t-1} \quad Y_t \quad (I)$$

: \gamma_P, \dots, \gamma_2, \gamma_1, \gamma_0

$$\gamma_0 = E (Y_t \cdot Y_t) = E(Y_t^2) = \theta_1 Y_1 + \theta_2 Y_2 + \dots + \theta_P Y_P + \delta^2_\varepsilon$$

$$\gamma_1 = E (Y_t \cdot Y_{t-1}) = \theta_1 Y_0 + \theta_2 Y_1 + \dots + \theta_P Y_{P-1}$$

$$\gamma_2 = E (Y_t \cdot Y_{t-2}) = \theta_1 Y_1 + \theta_2 Y_0 + \theta_3 Y_1 + \dots + \theta_P Y_{P-2}$$

:

:

$$\gamma_P = E (Y_t \cdot Y_{t-P}) = \theta_1 Y_{P-1} + \theta_2 Y_{P-2} + \dots + \theta_P Y_0$$

: () (II)

$$\rho_1 = \theta_1 + \theta_2 \rho_1 + \dots + \theta_p \rho_{p-1}$$

$$\rho_2 = \theta_1 \rho_1 + \theta_2 + \dots + \theta_p \rho_{p-2}$$

:

:

$$\rho_p = \theta_1 \rho_{p-1} + \rho_{p-2} + \dots + \theta_p$$

$$\theta_p \dots \theta_2, \theta_1 : \rho_k$$

: -2-1-2

$$\theta' = (\theta_1, \theta_2, \dots, \theta_p) : \text{(MCO) OLS}$$

: (AR (2) :) 2

$$X_t = \theta_1 X_{t-1} + \theta_2 X_{t-2} + \varepsilon_t$$

: t = 3

$$Y_3 = \theta_1 Y_2 + \theta_2 Y_1 + \varepsilon_3$$

$$Y_4 = \theta_1 Y_3 + \theta_2 Y_2 + \varepsilon_4$$

:

:

$$Y_t = \theta_1 Y_{t-1} + \theta_2 Y_{t-2} + \varepsilon_t$$

:

$$\begin{bmatrix} Y_1 \\ Y_2 \\ \vdots \\ Y_t \end{bmatrix} = \begin{bmatrix} Y_2 & Y_1 \\ Y_3 & Y_2 \\ \vdots & \vdots \\ Y_{t-1} & Y_{t-2} \end{bmatrix} \begin{bmatrix} \phi_1 \\ \phi_2 \end{bmatrix} + \begin{bmatrix} \varepsilon_3 \\ \varepsilon_4 \\ \vdots \\ \varepsilon_t \end{bmatrix}$$

$$Y = X \cdot \Phi + \Sigma$$

$$\theta^{\wedge} = (X'X)^{-1}X'Y : \text{MCO } \theta_2, \theta_1$$



:

-2-2

)

ARMA (P, q) MA (q)

:

$$Y_t - \phi_1 Y_{t-1} - \dots - \phi_p Y_{t-p} = \varepsilon_t + \theta_1 \varepsilon_{t-1} + \dots + \theta_q \varepsilon_{t-q}$$

(itérative)

:

-1-2-2

$$q \leq 2$$

θ

(GAUSS - NEWTON)

-

-2-2-2

:

$$\text{MIN} : S(\phi, \theta) = \sum e_t^2 = \sum (\varepsilon_t / \phi, \theta, Y_t)$$

(TAYLOR)

$$S(\phi, \theta)$$

$$\theta \quad \phi$$

(1)

:()

-3-2-4-3-II

:

:

-(1)

:

:

-(2)

. 163

,

-(1)

: (test de normalité)

(1)

T :) 1/T

$r_k : r_k \sim N(0, 1/T) :$

(2)

$-2/\sqrt{T} \leq r_k \leq +2/\sqrt{T} :$

H₀:

H₁:

: SKEUNESS *

$V_1 = (B_1^{1/2} - 0) / \sqrt{6/n} :$

$B_1^{1/2} \sim N(0, \sqrt{6/n}) : B_1^{1/2} = \mu_3 / \mu_2^{3/2}$

H₀ $\Leftrightarrow 1.96 < |V_1|$

H₁ $\Leftrightarrow 1.96 > |V_1|$

: KURTOSIS *

$V_2 = (B_2 - 0) / \sqrt{24/n} :$

$\mu_k = 1/n \sum (X_i - \bar{X})^k$

$B_1^{1/2} \sim N(0, \sqrt{24/n}) : B_2 = \mu_4 / \mu_2^2$

K : μ_k

169

(1)
(2)

$$H_0 \Leftrightarrow 1.96 < |V_2|$$

$$H_1 \Leftrightarrow 1.96 > |V_2|$$

: **: Jacque- bera**

$$H_0 \Leftrightarrow \chi^2 < JB$$

$$H_1 \Leftrightarrow \chi^2 > JB$$

$$JB = n/6 \cdot B_1^{1/2} n/24 (B_2 - 3)^2 :$$

: **: (LB)**

$$H_0: r_1 = r_2 = \dots = r_k = 0$$

$$H_1 \exists r_i \neq 0 \quad i = 1 \dots k$$

:

$$. q \quad P \quad : P + q :$$

: k

$$. t \quad : e_t \quad r_k = \sum e_t e_{t-k} / \sum e_t^2$$

:

$$. (r_k) \quad) H_0 \Leftrightarrow Q < \chi^2_{k-(P+q)} :$$

$$. (r_k) \quad) H_0 \Leftrightarrow Q > \chi^2_{k-(P+q)} :$$

: **: Ljung – Box - Pierce**

$$Q^* = T(T + 2) \sum (T - i)^{-1} r_i^2 \sim \chi^2_{K-(P+q)}$$

:

$$. H_0 \Leftrightarrow Q^* < \chi^2_{k-(P+q)} :$$

$$. H_1 \Leftrightarrow Q^* > \chi^2_{k-(P+q)} :$$

$$Q^* \quad Q$$



:

-2

() F () t

. $X^2 \sim N(0, 1)$

:

-1-2

:

$H_0 : B_j = 0$

$H_1 : B_j \neq 0$

$| \hat{B}_j - B_j | / \sigma_{\hat{B}_j} \sim N(0, 1) :$

. $B_j :$

. \hat{B}_j

. $\sigma_{\hat{B}_j}$

: $(B_j = 0) H_0$:

$H_0 \quad H_1 \quad \Leftarrow \quad B_j \quad \Leftarrow \quad | \hat{B}_j | / \sigma_{\hat{B}_j} < N(0, 1)$

$H_1 \quad H_0 \quad \Leftarrow \quad (\quad B_j) \quad B_j \quad \Leftarrow \quad | \hat{B}_j | / \sigma_{\hat{B}_j} > N(0, 1)$

:

-2-2

:

$H_0 : B_1 = B_2 = \dots = B_m = 0$

$H_1 \exists B_j \neq 0, j = 1 \dots m$

$S = RRSS - URSS / (URSS/T) \sim \chi^2_m :$

.

: m

:

.

$H_1 \quad H_0$

: URSS RRSS

:

$H_1 \quad H_0 \quad \Leftarrow \quad S > \chi^2_m$

(B_j :) $H_1 \quad H_0 \quad \Leftarrow \quad S < \chi^2_m$



: -3

2 1

:

:⁽¹⁾ AIC -1-3

$$AIC = \sigma^2 \exp \{2(p+q / 2)\} :$$

$$:) \quad \sigma^2 = S^2 :$$

$$: P + q \quad : \quad \sigma^2 = RSS / T :$$

$$NAIC = AIC / T :$$

. NAIC AIC

:⁽²⁾ (BIC SHWARZ) -2-3

$$BIC = \ln \sigma^2 + ((p+q)/T) \ln T : \quad SHWARZ$$

(BIC)

$$BIC = \ln \sigma^2 + \{ (p+q / T) \ln T$$

: -4- 2 - 4 -3 - II

:

" "

()

q , d , p ARIMA

: CHOW RAMSEY :

:

. TSP - EVIEWS
. TSP - EVIEWS

akaike information criterion : AIC -(1)
Naik information criterion : NAIC -(2)

$$Y_t = \hat{a}_0 + \hat{a}_1 x_{1t} + \hat{a}_2 x_{2t} + \dots + \hat{a}_k x_{kt}$$

$$\forall t = 1 \dots n$$

$$n = n_1 + n_2 \quad ; \quad n_2 \quad ; \quad n_1 \quad ; \quad (1)$$

$$Y_t = \hat{a}^1_0 + \hat{a}^1_1 x_{1t} + \hat{a}^1_2 x_{2t} + \dots + \hat{a}^1_k x_{kt}$$

$$\forall t = 1 \dots n_1$$

$$Y_t = \hat{a}^2_0 + \hat{a}^2_1 x_{1t} + \hat{a}^2_2 x_{2t} + \dots + \hat{a}^2_k x_{kt}$$

$$\forall t = 1 \dots n_2$$

$$\left\{ \begin{array}{l} H_0 : a_0 = a^1_0 = a^2_0, a_1 = a^1_1 = a^2_1, \dots, a_k = a^1_k = a^2_k \\ H_1 : \exists a^k_1 \neq a^k_2 \end{array} \right.$$

$$F_c = \frac{[SCR - (SCR_1 + SCR_2)] / (K + 1)}{(SCR_1 + SCR_2) / (n - 2(k + 1))}$$

$$(n = n_1 + n_2) \quad n \quad ; \quad SCR \quad ;$$

$$n_1 \quad ; \quad SCR_1$$

$$n_2 \quad ; \quad SCR_2$$

:K

:

$$n_2 \quad n_1 \quad) \quad H_1 \quad H_0 \quad F_t < F_c$$

$$F_t = F_{(k+1, n-2(k+1))} :$$

III - 1 - 1 :

III - 1 - 1 - 1 :

(1) :

:

:

:

:

1988

:

-1

1994

(2)

98-96

-2

383773

(1) - دادي عدون ناصر، اقتصاد المؤسسة (ط2 ؛ الجزائر : منشورات المحمدية، 2002)، ص 156

(2) - قدي عبد المجيد، "الاقتصاد الجزائري والشراكة الأجنبية خارج المحروقات" في أعمال الملتقى الوطني الأول حول المؤسسة الاقتصادية،

جامعة ورقلة، افريل 2003، ص ص 01 - 12.



%10.3

1992

%22.8

-3

%50

4/5

-4

-5

-6

:

.2000 %19.8

•

2000 25.3

•

2000 %0.34

•

1999

4.6

12

•

15

(75=\$1)

•

...

•

. %4 - %3 1995

•

;

-

-

III - 1-2 -

:

()

(1)

()

(2)

(.... - - -

59-58

.1977

(S.C.E.A

)

(3)

:

III - 1-3 -

:

(

:(C)

. (CFIM)

(4)

- :

: (Y_d) *

Y_d = Y - T + R : (R) (T) :

(RND)

: (Y) *

: 03

(1a PIB)

(1e PIB)

1a PIB = ΣVA + TVA + DT/M : -

: ΣVA :

: TVA

: DT/M

1a PIB = CF + ABFF + ΔS + X - M : -

: ABFF

: CF :

: M

: X

: ΔS

1a PIB = RS + CFF + ILP + ENE : -

() : RS :

() : CFF

: ILP

() : ENE

: (I) *

S.C.E.A

ABFF

(I = ABFF + ΔS :) ΔS

: (i) *

(1)

: (S) *

(épargne net)

S=Y_d - C :

: (T) *

: (G) *

... -

:(M) *

: S.C.E.A .

:(X) *

: S.C.E.A

:

(1) - بن عبد العزيز فطيمة ، مرجع سابق ، ص 120 .
(2) - عزي لخضر ، سعر الصرف وتدهور قيمة الدينار - حالة الجزائر - أطروحة ماجستير ، غير منشورة ، جامعة الجزائر ، كلية العلوم الاقتصادية ، 1997/96 ، ص 112 .

جدول (02) :

()	()	
CFIM		C
RND		Yd
La PIB		Y
ABFF+ ΔS	+	I
MBB		i
IB et S		M
EB et S		X
RP		T
DE+DG	+	G
E N		S

: _____
: - 2- III
: () - 1- 2- III

(ONS)

2001 1970 - - :
: ()

C - Yd - Y - I - i - M - X - G - T - S - R :

: _____ 2001 1970 : (03)

	Ct	Yd	I	i	Y	T	G	M	X	S
1970	13388.5	14107.6	8751.6	2.5	21210.2	5876	9468.2	6972.3	5323.3	-
1971	14026.5	15034.8	8887.1	2.5	21628.2	6941	9892.9	6871.9	4578.2	-
1972	16721.8	17616.8	10441.1	2.75	26521.8	8197	11333.45	7703	6166.8	-
1973	17741.1	18699.4	13940.5	2.75	30532.6	9989	14896.05	10857.3	8750	-
1974	23924.5	50529.7	22075.2	2.75	55560.9	4076.6	29731.25	19500.7	21403.1	18876.2
1975	29522.4	56899.4	27837.6	2.75	61573.9	5578.5	37696.45	26361.8	20714.1	17477.2
1976	34010.5	67532.5	31926.5	2.75	74075.1	7500.9	43021.25	27322.2	24362.8	22353.5
1977	42646	78937.8	40814	2.75	87240.5	9049.9	54337.15	36298.9	26553.5	22730

1978	48793.2	95176.4	54621.7	2.75	104831.6	10478.8	71221.05	41874.8	26689.4	29701.8
1979	56216.6	114318.8	54431.3	2.75	128222.6	14768.2	74076.55	41981.6	39908.3	38354.3
1980	67816.5	145017.7	63512	2.75	162507.2	18325.1	88106.45	49299.3	55880.8	52486.9
1981	84570.3	171962.5	70835.7	2.75	191468.5	20734.3	99746.55	59032.9	66181.8	58432.7
1982	92648.5	184528	77342.4	2.75	207551.9	24181	110862.8	60185.4	64223.3	58309.1
1983	103048	207298.7	87819	2.75	233752.1	27327.6	125563.3	60205.8	65343.9	66423.2
1984	122373	234886.5	92531.5	2.75	263855.9	29703.4	135350.8	61558.1	67688	69581.7
1985	136423	258403.4	96765.4	2.75	291597.2	34876.2	146003.8	59462.2	68629.8	72851.9
1986	152195	261707.1	99333.3	2.75	296551.4	38262.2	156471.9	50832.5	38714.2	52402.2
1987	149866	275195.4	93880.2	5	312706.1	39868.9	156963.2	39961.8	45834	62317.7
1988	208876	334347.6	98040.2	5	347716.9	44302.5	168392.1	79453.4	49897.5	55115
1989	257270	424954.3	128766	6	422043	45627.1	207775.2	121066	78057.9	88669.3
1990	305042	543473.6	160217	8.75	554388.1	58295.2	258854.2	139110	129593	139785
1991	410050	812210.6	266734	11	862132.8	96035	403893.9	198354	246532	264990
1992	538845	1023832	319811	11.5	1074696	103458	514041.6	244492	266290	290745
1993	639068	1107132	336203	11.5	1189725	139076	567472.1	269126	252299	236784
1994	826755	1407804	467941	17.63	1487404	179489	742571.9	424503	342567	306405
1995	1100726	1877458	633031	18	2004995	243336	987305.1	616099	533047	422356
1996	1319214	2346683	644641	16.33	2570029	314226	1065818	596710	781688	606274
1997	1411670	2570235	647459	14	2780168	313607	1125965	594683	837217	680060
1998	1531503	2590658	773955	9.25	2830491	333751	1302810	656080	652257	530301
1999	1642339	2919215	849951	8.5	3238198	413135	1421932	737629	911556	704896
2000	1684863	3732734	944964	8.5	4098816	438508	1534425	855222	1734751	1458410
2001	1817277	3925928	1149291	8	4243803	423339	1806301	930678	1550898	1453638

(2001 -1970)

‘

:

(IPC)

(1)

. IPC

(1989

) 1990

. 1990

1970

:

IPC

2001 1990 (IPC)

: (04)

01	00	99	98	97	96	95	94	93	92	91	90	
578.2	558.7	562.2	550.7	518.4	488.8	406.2	316.3	240.2	197.5	150.8	120.2	

(www.ons.dz)

ONS : _____

IPC 2001 1990

()

: (05)

/	CT	YD	I	Y	T	G	M	X	S
1990	2537.79	4521.41	1333	4612.21	484.99	2153.53	1157.32	1078.14	1162.94
1991	2719.16	5386.01	1769	5717.06	636.84	2678.34	1315.35	1634.83	1757.23
1992	2728.33	5183.96	1619	5441.5	523.84	2602.74	1237.93	1348.3	1472.13
1993	2660.56	4609.21	1400	4953.06	579	2362.5	1120.42	1050.37	985.779
1994	2613.83	4450.85	1479	4702.51	567.46	2347.68	1342.09	1083.05	968.717
1995	2709.81	4622	1558	4935.98	599.05	2430.59	1516.74	1312.28	1039.77
1996	2698.88	4800.91	1319	5257.83	642.85	2180.48	1220.76	1599.2	1240.33
1997	2723.13	4958.02	1249	5362.98	604.95	2172	1147.15	1615	1311.84
1998	2781.01	4704.3	1405	5139.81	606.05	2365.73	1191.36	1184.41	962.958
1999	2921.27	5192.48	1512	5759.87	734.85	2529.23	1312.04	1621.41	1253.82
2000	3015.68	6681.11	1691	7336.35	784.87	2746.42	1530.74	3104.98	2610.36
2001	3142.99	6789.91	1988	7339.68	732.17	3124.01	1609.61	2682.29	2514.07

(IPC

)

: _____

: C_t

(

(15)

1985

103.04

13.38

1970

15

2001

1986

(2001 -90

)

"

"

"

96-94-93 :

"



2000

30.38

1990 89

25 24.4

الشكل (15) :

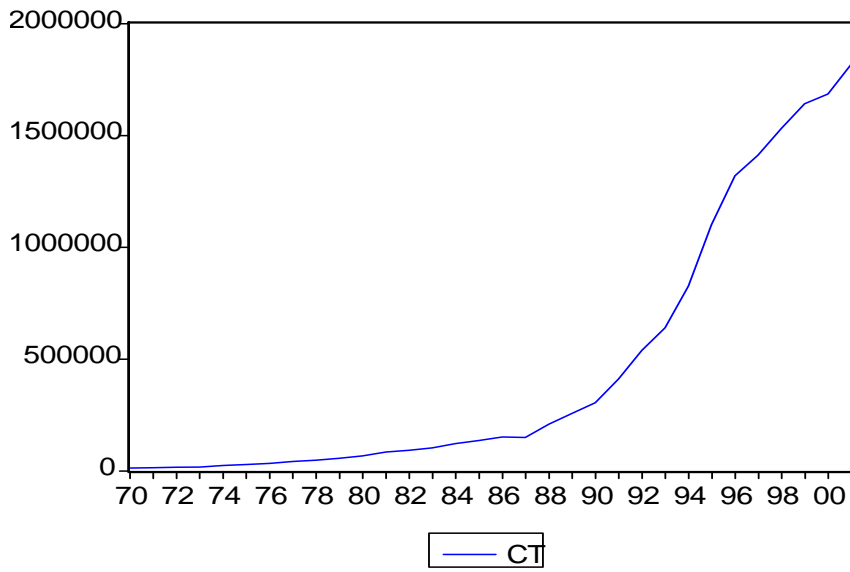

()

الشكل (16) :

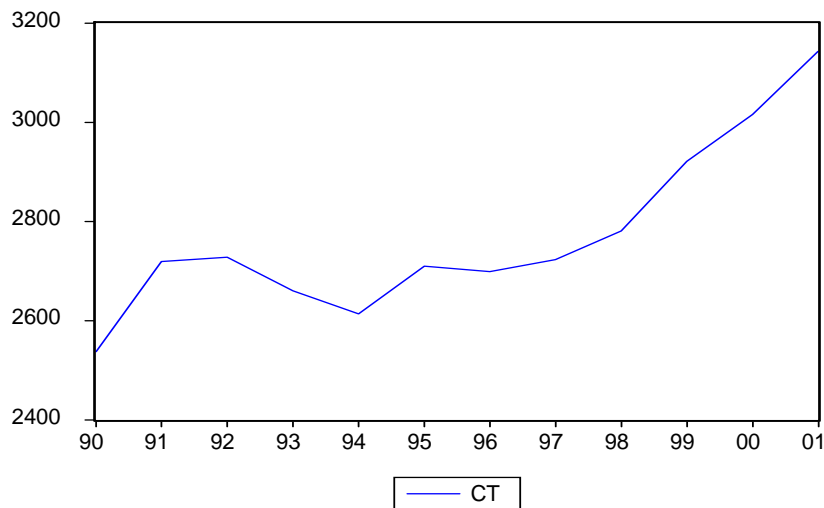

(TSP - EIEWS)

)

:

(Y)

(

(17)

:

الشكل (17) : منحنى الدخل الوطني

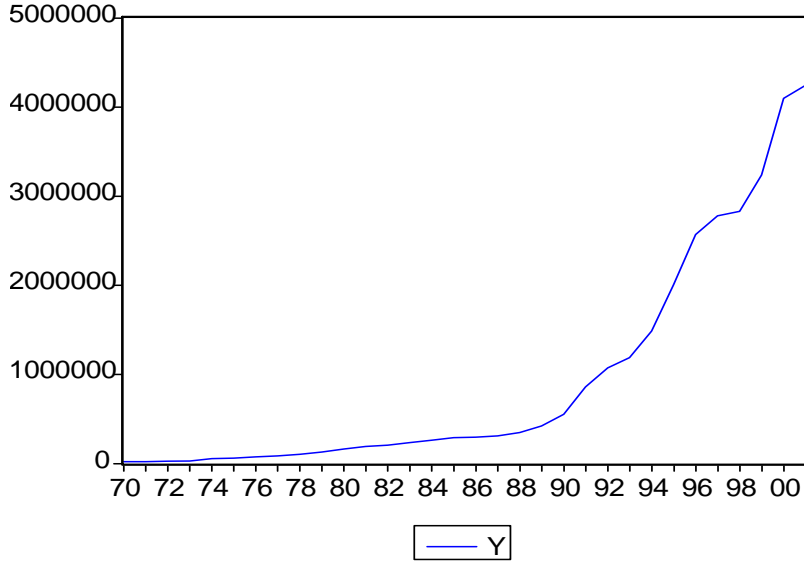

(TSP – EViews) : _____

(LA PIB)

1989 260.75 1970 21.21

1999 98

(18)

95-94-93

92 91

1990

. 2001 2000

2000

1/4

96-95-94

% 28.5 %25.5 ; %22.5

(1)(

-

-

-

:

() OPEC

(1) - قدي عبد المجيد ، مرجع سابق ، ص 08

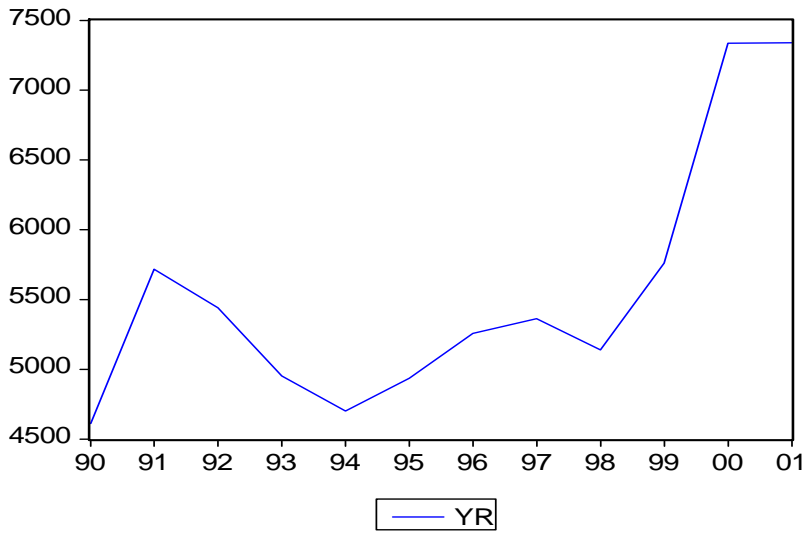

الشكل (18) :
منحني الدخل
الوطني (بالقيم الحقيقية)

(TSP – EIEWS) : _____

(Yd) (

(T) (Y)

(03) . $Y_d = Y - T + R$: (R)

(Yd)

(20 19) ; (Y)

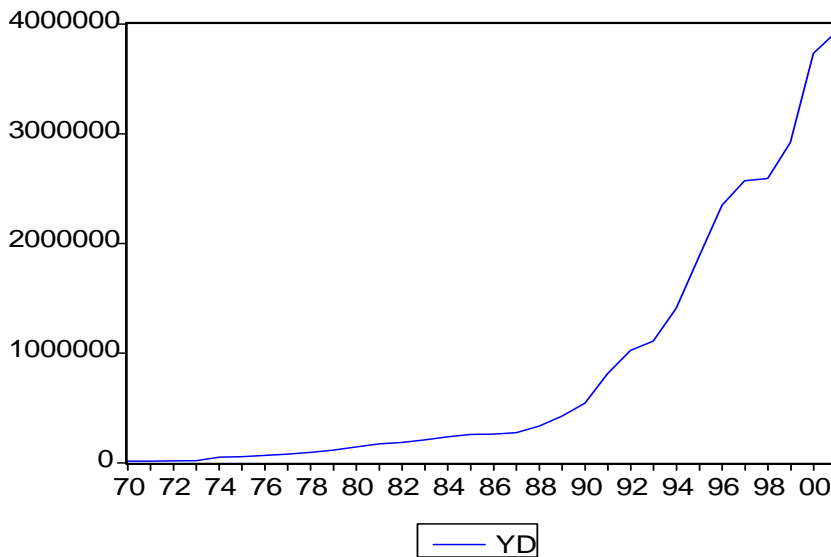

الشكل (19) :

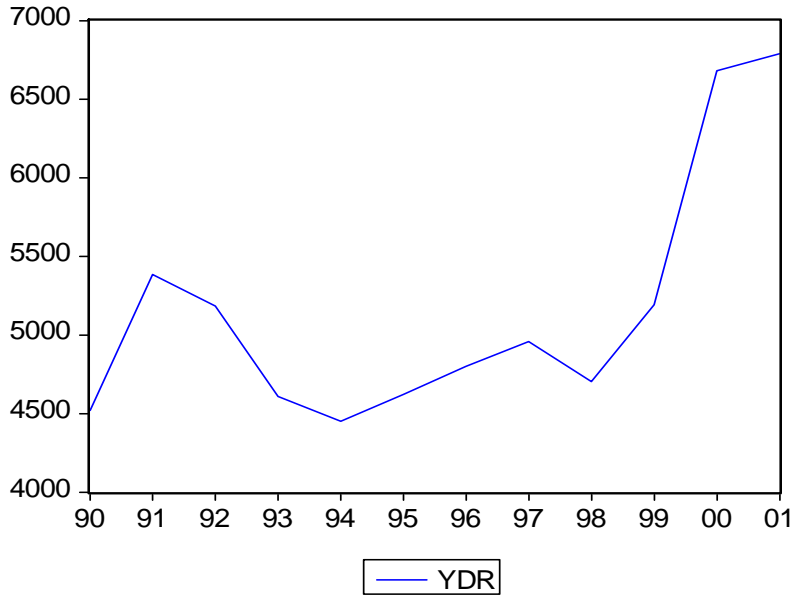

الشكل (20) :
منحنى الدخل
الوطني المتاح
(بالقيم الحقيقية)

(TSP – EIEWS) : _____

(I) :

(03)

;

:

(1)

(ΔS) (ABFF) :

:(21)

(1) - لبشير عبد الكريم : تطور الانفاق الاستثماري في الجزائر و علاقته بالمر دودية في أعمال الملتقى الوطني الأول حول المؤسسة الاقتصادية ، جامعة ورقلة ، 2003 ، ص 08 .

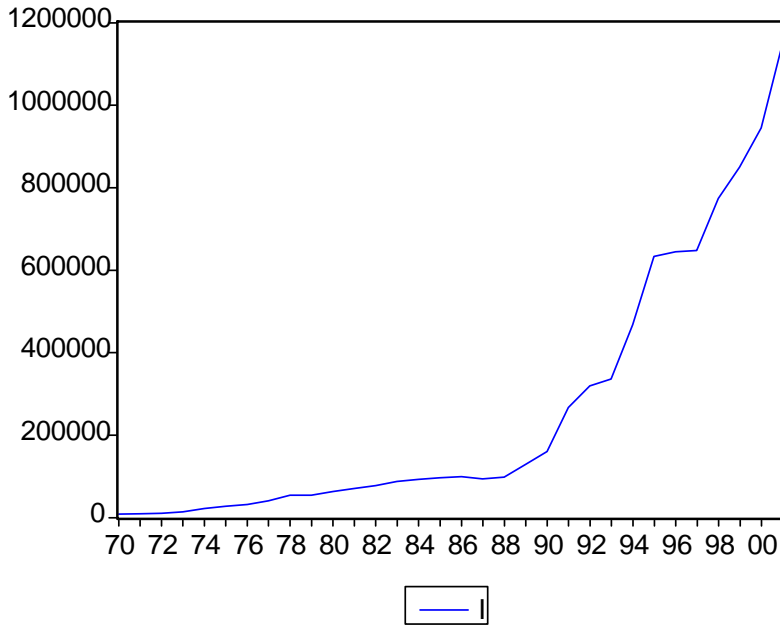

الشكل (21) :

(TSP – EIEWS) : _____
1970

97-96 93-92

: (22)

97 91 90

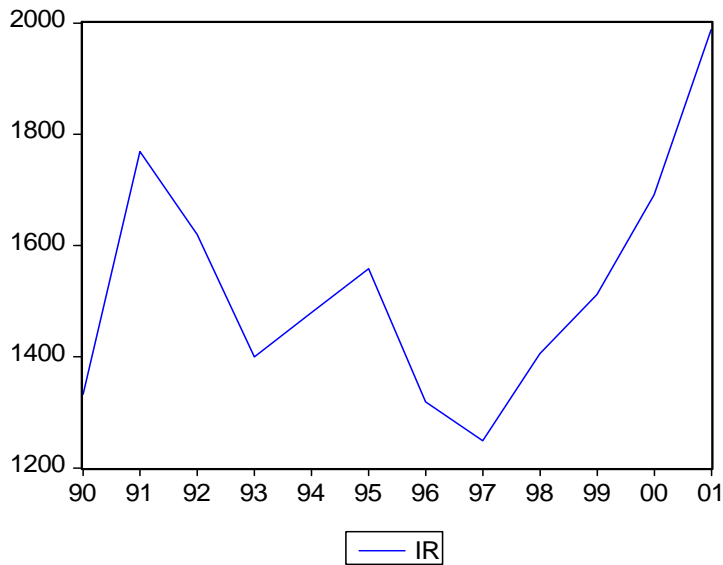

الشكل (22) :
منحني الاستثمار
الوطني (بالقيم
الحقيقية)

(TSP – EIEWS) : _____

() ENAD- HINKL :

()

()

:(1)

12-93

-
-
-
-

.1997

: (i)

(

(1)- قدي عبد المجيد ، مرجع سابق ، ص 10

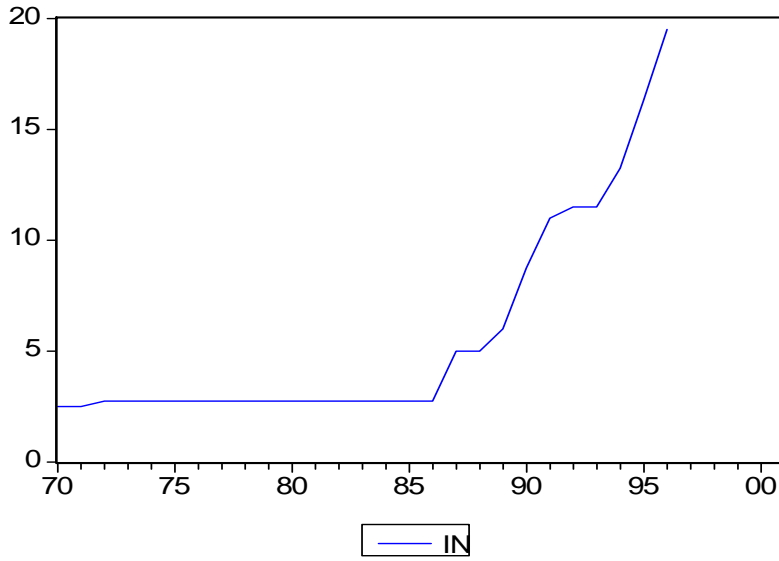

الشكل (23) :

(TSP – EIEWS) : _____
 %2.75 1986 1972

، (71 70 %2.5)
 10-90 1986

(1) :

	% 20	←
% 10.5	1989	% 07 ←
	1992	% 11.5 1991 ←

(T) :

1970

(1) - شعوبي، م. فوزي و كعاسي . م. الأمين، " الاقتصاد الجزائري من منظور متغيرات حساب الإنتاج وحساب الاستغلال للفترة بين 89-99 " في أعمال الملتقى الوطني الأول حول المؤسسة الاقتصادية ، جامعة ورقلة ، افريل 2003 ، ص ص 4- 5

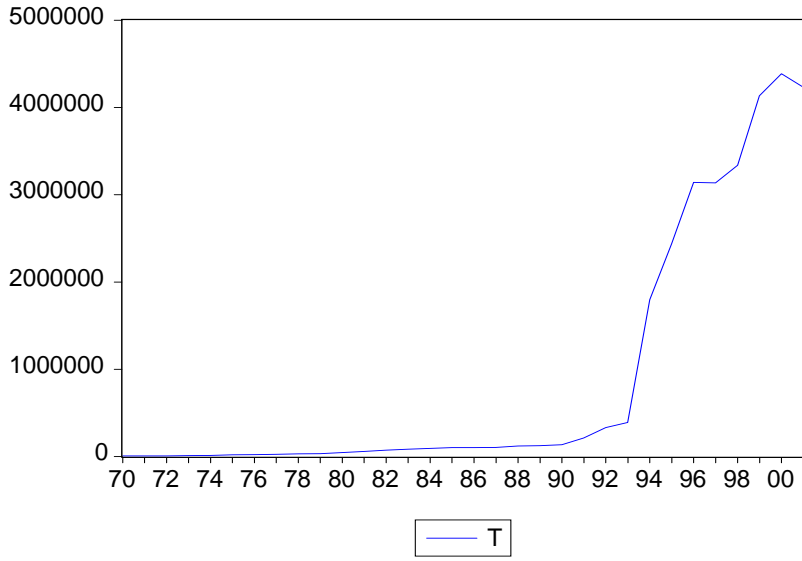

الشكل (24) :

(TSP - EVIEWS) : _____
: (1)

45 1993

/

49 1995

...

%40

.%21

%6

(1) - قدي عبد المجيد ، مرجع سابق ، ص 07

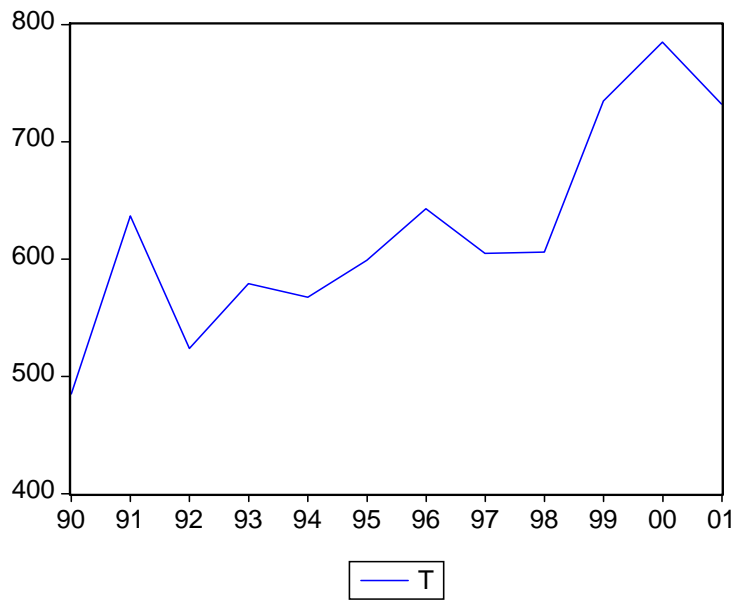

الشكل (25) :

()

(TSP – EIEWS) : _____

: (G) ()

()

... - - :

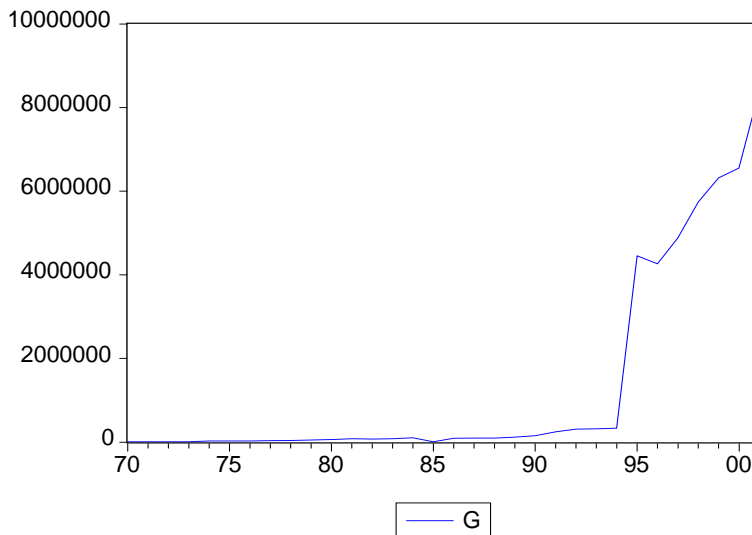

الشكل (26) :

(TSP – EIEWS) : _____

(+)
 1990 %8 1988 %19 1985 %28.2
 ... 90 88 % 5.2

(1).

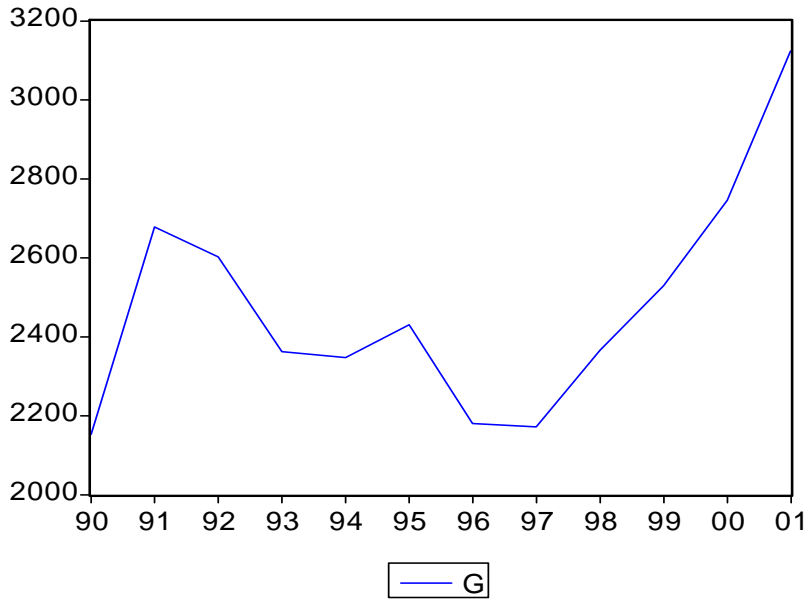

الشكل (27) :

()

(TSP – EIEWS) : _____
 : (M) ()
 :

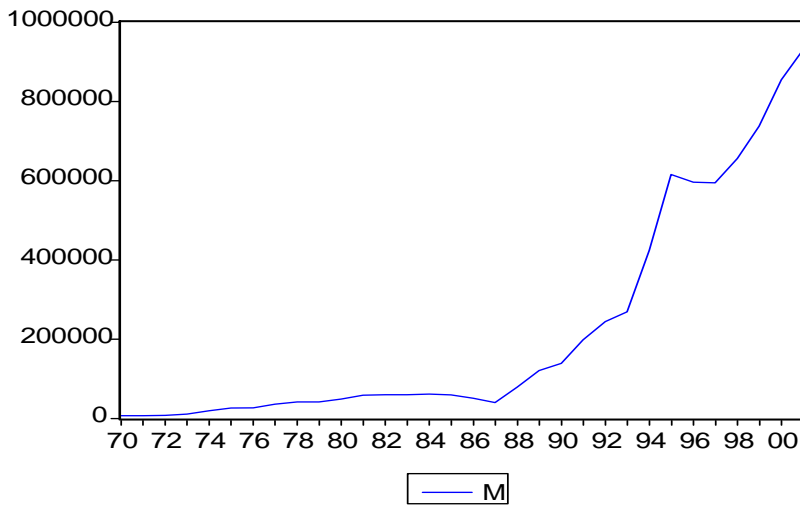

الشكل (28) :

TSP – _____
 (EIEWS)

(1) - شعوبي.م.فوزي و كماسي .م. الأمين ، مرجع سابق ، ص 6

- - - :

:

2003 - 1970 (%) : (06)

2003	1991	1980	1970	/
20	24.88	19.2	10.25	
15.6	15.5	6.65	8	
27.3	30.27	33.7	39	
37.1	29.7	38.25	41	
-	-	2.2	1.85	

(ONS) : _____

.(.... - - :)

. 2003 19 91

(29)

1993 91 90

. 2001

1998

1995

الشكل (29) : منحني الواردات (بالقيم الحقيقية)

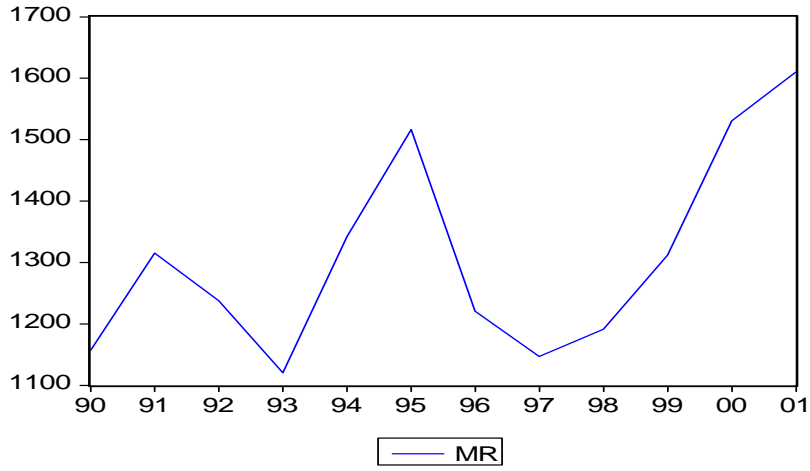

(TSP – EIEWS) : _____

(1)

(: (x))

()

1988 .

. 2001- 2000 98-97

. 93-91

(1) --شعوبي.م.فوزي و كعاسي .م. الأمين ، مرجع سابق ، ص 09

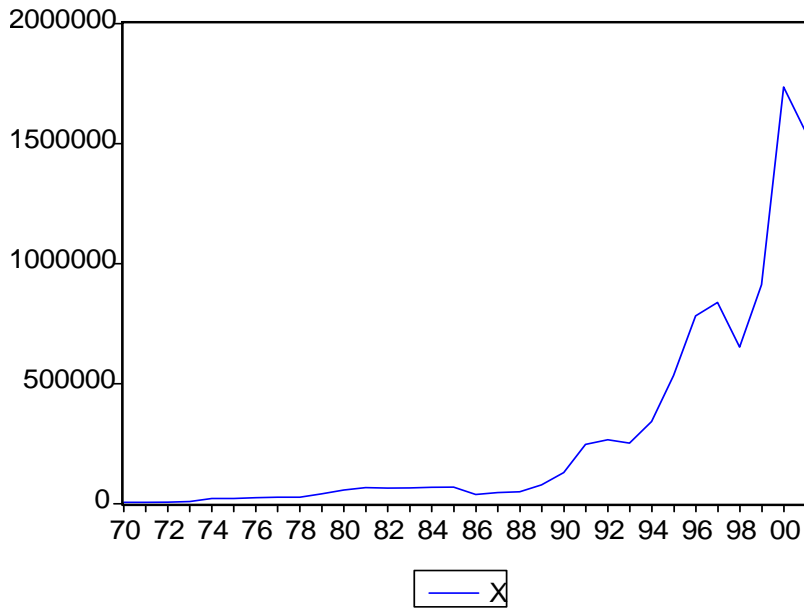

الشكل (30) :

(TSP - EViews) : _____

-(HALUBIRTON) :

... (BUKER) - (B P) - (ANADARKO)

()

)

:

. (31) (

- - :

:

-

2003 - 1970 (%) : (07)

2003	1991	1980	1970	/
0.8	0.75	0.8	19.80	
96.3	95.85	98.2	70.4	
0.9	0.7	0.9	3.2	
2.0	2.72	0.01	5.6	
-	-	0.04	1.0	

(ONS) :

%70.4

1980

. % 5.6 %19.8 ()

% 98 95

الشكل (31) : منحني الصادرات (بالقيم الحقيقية)

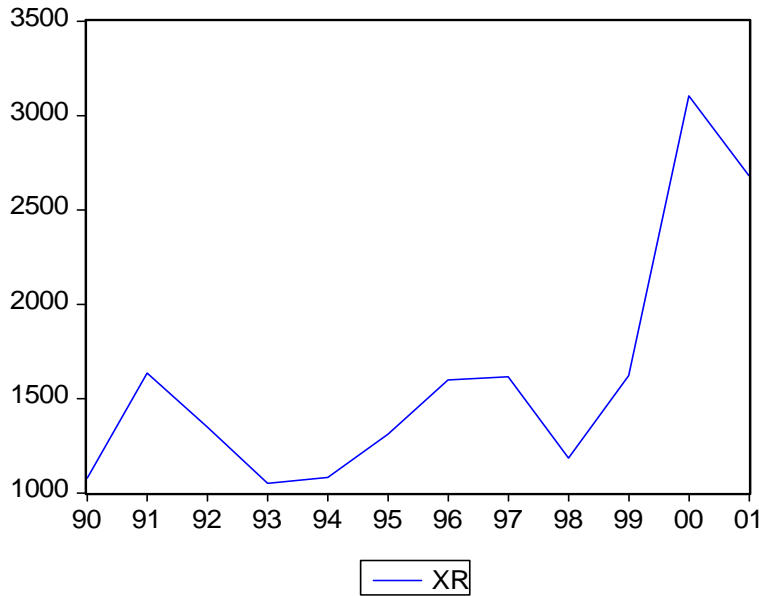

(TSP – EIEWS) :

(31)

(S) :

الشكل (32) :

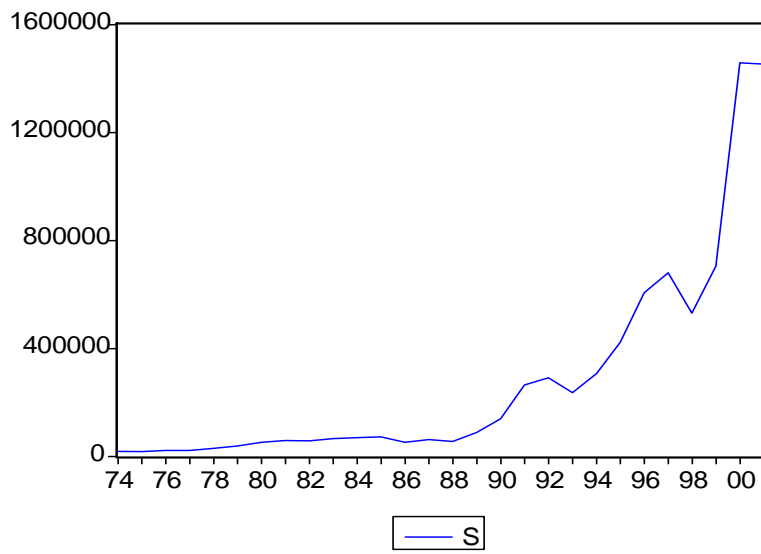

(TSP – EIEWS) : _____

:

)

()

(

-
-

الشكل (33) : منحنى الادخار (بالقيم الحقيقية)

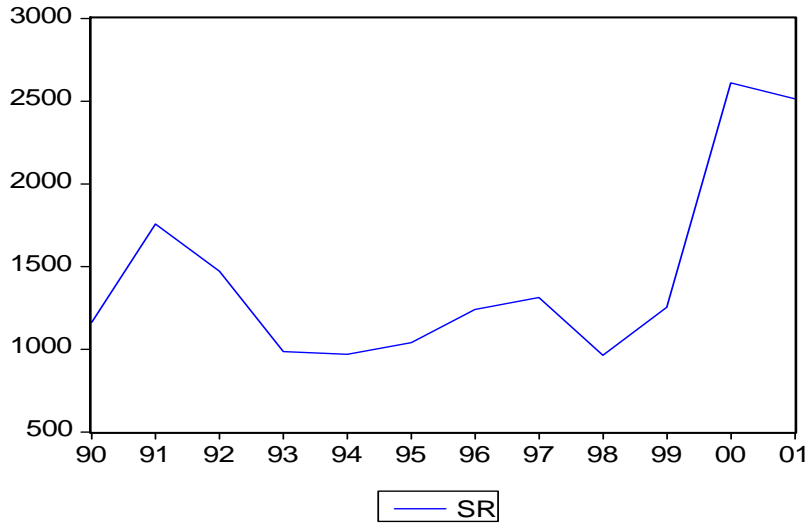

(TSP – EIEWS) : _____

: () - 2-2-III

(38)

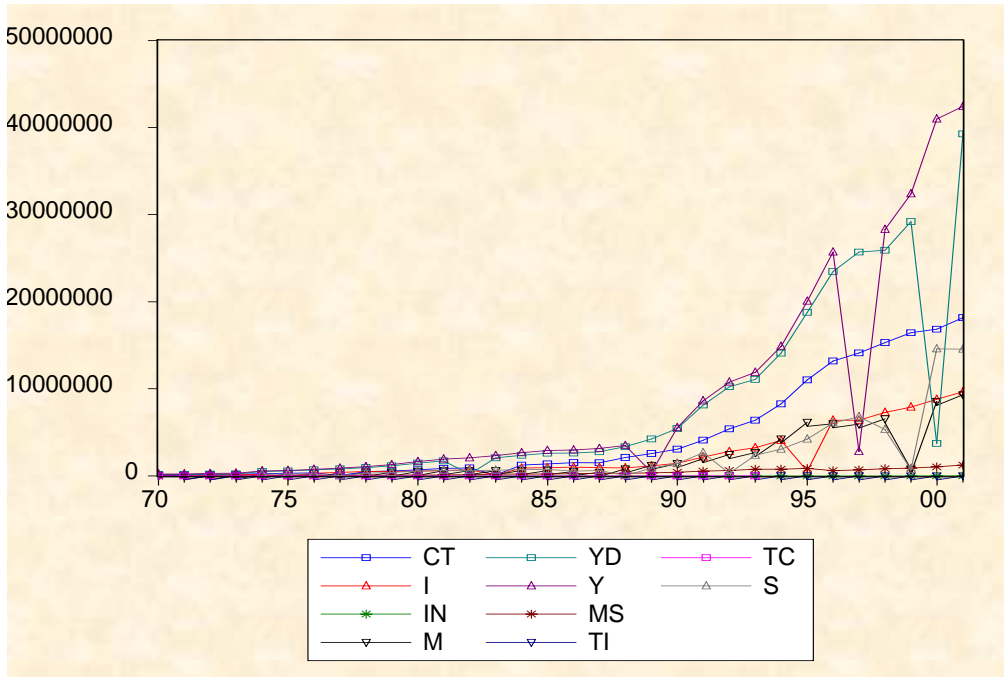

الشكل (38) :

1970

(1)

(CT) -(Yd) -(Y)

: () () (2)

19 86 1972

" ()

"



()

GRANGER

()

:

-

(Feed-back)

-

-

: - 3-2-II

GRANGER

:

GRANGER

•

GRANGER

:(Y_d)

(CT)

(1)

:

GRANGER

CT

Y_d : H₀

C T = f (Y_d) :

GRANGER

CT

Y_d : H₁

()

GRANGER

Y_d

CT : H₀

Y_d = f (CT_d) :

GRANGER

Y_d

CT : H₁

: Y_d CT

TSP- eviews

Pair wise Granger Causality Tests

Sample: 1970 2001

Lags: 2

Probability	F-Statistic	Obs	Null Hypothesis:
-------------	-------------	-----	------------------

0.06567	3.04246	30	YD does not Granger Cause CT
---------	---------	----	------------------------------

0.00037	11.0280		CT does not Granger Cause YD
---------	---------	--	------------------------------

:

CT	Yd :	H ₁	H ₀	(1) Ft > Fc ₁ = 3.024
----	------	----------------	----------------	----------------------------------

GRANGER

GRANGER	Yd	CT :	H ₁	H ₀	Ft < Fc ₁ = 11.02
---------	----	------	----------------	----------------	------------------------------

Yd = f (CT) :

GRANGER	:	(IN)	(I)	(2)
---------	---	------	-----	-----

:

GRANGER	I	IN : H ₀
---------	---	---------------------

I = f (IN) :	GRANGER	I	IN : H ₁
--------------	---------	---	---------------------

()

GRANGER	IN	I : H ₀
---------	----	--------------------

IN = f (I) :	GRANGER	IN	I : H ₁
--------------	---------	----	--------------------

: TSP- eviews

Probability	F-Statistic	Obs	Null Hypothesis:
-------------	-------------	-----	------------------

0.00432	6.82227	30	IN does not Granger Cause I
---------	---------	----	-----------------------------

0.91076	0.09382		I does not Granger Cause IN
---------	---------	--	-----------------------------

:

GRANGER	I	IN :	H ₁	H ₀	Ft < Fc ₁ = 6.822
---------	---	------	----------------	----------------	------------------------------

(1) - لا يهيم معرفة قيمة F_t من الجدول وإنما نستعمل احتمالها فقط المعطى حيث : p(F_t) > 0.05 يعني أننا نقبل H₀ ونرفض H₁

GRANGER IN I : H1 H0 Ft > Fc2 = 0.093

$$I = f(IN) :$$

GRANGER : (Y) (M) (3)

Probability F-Statistic Obs Null Hypothesis:

0.00016 12.6006 30 M does not Granger Cause Y

0.03477 3.85366 Y does not Granger Cause M

GRANGER Y M : H1 H0 Ft < Fc1 = 12.60

GRANGER M Y: H1 H0 Ft < Fc2 = 3.853

$$Y = f(M) \quad M = f(Y) :$$

$$. Y \quad M \quad (\quad)$$

$$: (1) \quad (\quad)$$

Yd S •

IN S •

Y T •

:

GRANGER

: (09)

M	T	I	S	CT	/
-	-	-	b	2	Yd
b	b	-	-	-	Y
-	-	1	×	-	IN

∴ _____

:

()

: -

: 1

()

: 2

: b

()

: ×

: GRANGER

()

*

: $Y_d = f(CT)$:

($CT = f(Y_d)$:) CT

Yd -

Y

M

()

*

‘ Yd

S

()

()

GRANGER

" :

"

)

:

: 1 0

D

(

$$D = \begin{cases} 0 \\ 1 \end{cases}$$

(1) (1989 1970)

: 0

.(1990)

: 1

:

$$C_t = c_{(1)} + c_{(2)} Yd_t + c_{(3)} Yd_{t-1} + c_{(4)} D_t + \varepsilon_{1t}$$

$$S_t = c_{(5)} + c_{(6)} Yd_t + c_{(7)} D_t + \varepsilon_{2t}$$

$$I_t = c_{(8)} - c_{(9)} \dot{I}_t + c_{(10)} D_t + \varepsilon_{3t}$$

$$T_t = c_{(11)} + c_{(12)} Y_t + c_{(13)} D_t + \varepsilon_{4t}$$

$$M_T = C_{(14)} + C_{(15)} y_t + c_{(16)} D_t + \varepsilon_{5t} \dots \dots \dots (II)$$

$$X_t = X_{0t} + c_{(17)} D_t + \varepsilon_{6t}$$

$$G_t = G_{0t} + c_{(18)} D_t + \varepsilon_{7t}$$

$$I_t + X_t + G_t = S_t + M_t + T_t$$

TSP-EVIEWS

.D

(1)- بسبب التغيرات التي حصلت على المستوى العالمي وعلى المستوى الوطني بعد 1989

$$\begin{aligned}
C_t &= c_{(1)} + c_{(2)} Yd_t + c_{(3)} Yd_{t-1} + \varepsilon_{1t} \\
S_t &= c_{(4)} + c_{(5)} Yd_t + \varepsilon_{2t} \\
I_t &= c_{(6)} - c_{(7)} \dot{I}_t + \varepsilon_{3t} \\
T_t &= c_{(8)} + c_{(9)} Y_t + \varepsilon_{4t} \quad \dots\dots\dots(III) \\
M_T &= C_{(10)} + C_{(11)} Y_t + \varepsilon_{5t} \\
I_t + X_t + G_t &= S_t + M_t + T_t
\end{aligned}$$

OLS () MCO

:

_____ :
(1)

Granger

$$\begin{aligned}
S_T &= C_{(4)} + C_{(5)} Yd_t + \varepsilon_{2t} \dots\dots(1) \\
Yd_t &= C_{(4)'} + C_{(5)'} S_T + \varepsilon_{2t}' \dots\dots(2)
\end{aligned}$$

$$S_T \quad (1) \quad \varepsilon_{2t}$$

$$. (2) \quad Yd_t$$

$$Yd_t \quad \varepsilon_{2t}$$

$$(\Delta Yd_t \quad \Delta S_T \quad \Delta \varepsilon_{2t} :)$$

$$. COV(x_i, \varepsilon_i) = 0 \quad MCO$$

$$Yd_t \quad (2) \quad \varepsilon_{2t}' \quad (2)$$

$$C_t$$

(3)

$$M_T = C_{(10)} + C_{(11)} Y_t + \varepsilon_{5t} \dots\dots(1)$$

$$Y_t = C_{(10)'} + C_{(11)'} M_T + \varepsilon_{5t}' \dots\dots(2)$$



$$M_T \quad (1) \quad \varepsilon_{5t}$$

$$(2') \quad Y_t$$

$$Y_t \quad \varepsilon_{5t}$$

MCO

$$(\Delta Y_t \quad \Delta M_T \quad \Delta \varepsilon_{5t} :)$$

$$COV(x_i, \varepsilon_i) = 0$$

$$(2) \quad \varepsilon_{5t}' \quad (2)$$

$$T_t \quad Y_t$$

:

$$: \quad \underline{-1 - 3- III}$$

:(III)

$$: \quad ($$

:

$$- C_t + c_{(1)} + c_{(2)} Y_{dt} + c_{(3)} Y_{dt-1} \varepsilon_{1t} = 0$$

$$- S_t + c_{(4)} + c_{(5)} Y_{dt} + \varepsilon_{2t} = 0$$

$$- I_t + c_{(6)} - c_{(7)} \dot{I}_t + \varepsilon_{3t} = 0$$

$$\Rightarrow - T_t + c_{(8)} + c_{(9)} Y_t + \varepsilon_{4t} = 0 \quad \dots (III)$$

$$- M_T + c_{(10)} + c_{(11)} y_t + \varepsilon_{5t} = 0$$

$$-I_t - X_t - G_t + S_t + M_t + T_t = 0$$

$$: (\quad) \quad ($$

: - -

	G	X	M	Y	T	IN	I	S	Y _d	Y _{d-1}	C	
c ₍₁₎	0	0	0	0	0	0	0	0	c ₍₂₎	c ₍₃₎	1-	1
c ₍₄₎	0	0	0	0	0	0	0	1-	c ₍₅₎	0	0	2
c ₍₆₎	0	0	0	0	0	-c ₍₇₎	1-	0	0	0	0	3
c ₍₈₎	0	0	0	c ₍₉₎	1-	0	0	0	0	0	0	4
c ₍₁₀₎	0	0	1-	c ₍₁₁₎	0	0	0	0	0	0	0	5
0	1-	1-	1	0	1	0	1-	1	0	0	0	6

: () (

: (M-1) × (M-1)

(: M :)

$$C_t = c_{(1)} + c_{(2)} Y_{dt} + c_{(3)} Y_{d,t-1} + \varepsilon_{1t} \quad : \quad (1-$$

: - -

	G	X	M	Y	T	IN	I	S	Y _d	Y _{d-1}	C	
c₍₁₎	0	0	0	0	0	0	0	0	c₍₂₎	c₍₃₎	1-	1
c ₍₄₎	0	0	0	0	0	0	0	1-	c ₍₅₎	0	0	2
c ₍₆₎	0	0	0	0	0	-c ₍₇₎	1-	0	0	0	0	3
c ₍₈₎	0	0	0	c ₍₉₎	1-	0	0	0	0	0	0	4
c ₍₁₀₎	0	0	1-	c ₍₁₁₎	0	0	0	0	0	0	0	5
0	1-	1-	1	0	1	0	1-	1	0	0	0	6

(M-1) × (M-1)

()

5 × 5

: MATLAB :

$$\Delta_1 = \begin{vmatrix} 0 & 0 & 0 & 0 & -1 \\ 0 & 0 & -C_{(6)} & -1 & 0 \\ C_{(8)} & -1 & 0 & 0 & 0 \\ C_{(10)} & 0 & 0 & 0 & 0 \\ 0 & 1 & 0 & -1 & 1 \end{vmatrix} \neq 0$$

()

()

$$S_t = c_{(4)} + c_{(5)} Yd_t + \varepsilon_{2t} \quad : \quad (2-$$

	G	X	M	Y	T	IN	I	S	Yd	Yd-1	C	
$c_{(1)}$	0	0	0	0	0	0	0	0	$c_{(2)}$	$c_{(3)}$	1-	1
$c_{(4)}$	0	0	0	0	0	0	0	1-	$c_{(5)}$	0	0	2
$c_{(6)}$	0	0	0	0	0	$-c_{(7)}$	1-	0	0	0	0	3
$c_{(8)}$	0	0	0	$c_{(9)}$	1-	0	0	0	0	0	0	4
$c_{(10)}$	0	0	1-	$c_{(11)}$	0	0	0	0	0	0	0	5
0	1-	1-	1	0	1	0	1-	1	0	0	0	6

: 5x5

$$\Delta_2 = \begin{vmatrix} 0 & 0 & 0 & 0 & -1 \\ 0 & 0 & -C_{(6)} & -1 & 0 \\ C_{(8)} & -1 & 0 & 0 & 0 \\ C_{(10)} & 0 & 0 & 0 & 0 \\ 0 & 1 & 0 & -1 & 0 \end{vmatrix} \neq 0$$

()

()

$$: () \quad (3-$$

)

()

.)

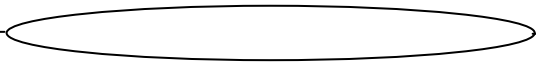

) M-1 K-F : •

: (

: -1

11 = K :

9 = K-F : 2 = F

5 = M-1 : 6 = M ()

. K- F > M-1 :

: -2

() M = 6 K = 11

: (10)

		M-1	K- F	F	
	6 < 9	6	9	2	2
"	6 < 9	6	9	2	3
"	6 < 9	6	9	2	4
"	6 < 9	6	9	2	5
	6 ≥ 5	6	5	6	6

: _____

()

: _____

: -2 - 3- III

()

:

TSP- EVIEWS

(MCO - OLS)

(1

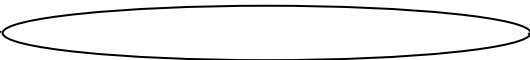

(MCR - WLS) - (2

(DMC-2SLS) (3

(DMCR- W2SLS) (4

(TMC- 3SLS) (5

(GMM-TS) (6

(GMM-CS)

(SURE)

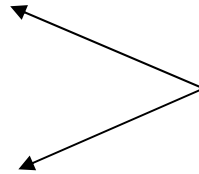

:TSP - EIEWS

11) -1

(2001 1970

system new objects objects -2

WLS OLS -3

(les variables instrumentales)

(inst =) inst

-4

:

(03)

:

$$C_t = C_{(1)} + c_{(2)} \cdot Yd_t + c_{(3)} \cdot Yd_{t-1}$$

$$S_t = C_{(4)} + C_{(5)} \cdot Yd_t$$

$$I_t = C_{(6)} - C_{(7)} \cdot I_t$$

$$T_t = C_{(8)} + C_{(9)}Y_t$$

$$M_T = C_{(10)} + C_{(11)} y_t$$

$$I_t + X_t + G_t = S_t + M_t + T_t$$

: (OLS)

Estimation Method: **Least Squares**

Sample: 1970 2001

.Prob	-Statistic t	Std. Error	Coefficient	
0.2144	1.246026	19356.25	24118.40	C(1)
0.0002	3.850359	0.111204	0.428174	C(2)
0.4647	0.732844	0.125583	0.092033	C(3)
0.2435	1.170264-	27881.95	32629.24-	C(4)
0.0000	17.42747	0.018140	0.316127	C(5)
0.7620	0.303308-	70729.13	21452.72-	C(6)
0.0000	5.016828-	8803.505	44165.67-	C(7)
0.4008	0.842242	3513.089	2958.870	C(8)
0.0000	49.53573	0.002245	0.111218	C(9)
0.1347	1.503084	8353.515	12556.04	C(10)
0.0000	41.62279	0.005339	0.222212	C(11)

E+576.84

Determinant residual covariance

Equation: $CT = C(1) + C(2) *YD + C(3)*YD(-1)$

Observations: 31



480194.9	Mean dependent var	0.981632	R-squared
601519.8	S.D. dependent var	0.980320	Adjusted R-squared
E+111.99	Sum squared resid	84384.82	S.E. of regression
		0.674281	Durbin-Watson stat

Equation: $S = C(4) + C(5)*YD$

Observations: 28

281454.5	Mean dependent var	0.921144	R-squared
393390.9	S.D. dependent var	0.918112	Adjusted R-squared
E+113.29	Sum squared resid	112573.4	S.E. of regression
		0.893303	Durbin-Watson stat

Equation: $I = C(6) - C(7)*IN$

Observations: 32

261773.4	Mean dependent var	0.456212	R-squared
321534.9	S.D. dependent var	0.438086	Adjusted R-squared
E+121.74	Sum squared resid	241025.6	S.E. of regression
		0.152963	Durbin-Watson stat

Equation: $T = C(8) + C(9)*Y$

Observations: 32

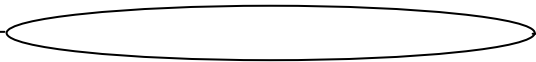

108185.0	Mean dependent var	0.987922	R-squared
141682.1	S.D. dependent var	0.987519	Adjusted R-squared
E+097.52	Sum squared resid	15828.45	S.E. of regression
		1.194747	Durbin-Watson stat

Equation: $M = C(10) + C(11) * Y$

Observations: 32

222796.5	Mean dependent var	0.982978	R-squared
283789.9	S.D. dependent var	0.982411	Adjusted R-squared
E+104.25	Sum squared resid	37637.31	S.E. of regression
		1.165298	Durbin-Watson stat

:

$$C_t = 24118.4 + 0.428 \cdot Y_{d_t} + 0.092 \cdot Y_{d_{t-1}}$$

$$S_t = 32629.24 + 0.316 \cdot Y_{d_t}$$

$$I_t = 21452.72 + 44165.67 \cdot \hat{u}_t$$

$$T_t = 2958.87 + 0.111 \cdot Y_t$$

$$M_T = 12556.04 + 0.222 \cdot Y_t$$

: (WLS)

/

OLS

:

Estimation Method: **Weighted Least Squares**

.Prob	t-Statistic	Std. Error	Coefficient	
0.1916	1.311080	18395.83	24118.40	C(1)
0.0001	4.051381	0.105686	0.428174	C(2)
0.4417	0.771105	0.119352	0.092033	C(3)
0.2262	1.214440-	26867.72	32629.24-	C(4)
0.0000	18.08535	0.017480	0.316127	C(5)
0.7545	0.313255-	68483.18	21452.72-	C(6)
0.0000	5.181358-	8523.957	44165.67-	C(7)
0.3856	0.869864	3401.533	2958.870	C(8)
0.0000	51.16029	0.002174	0.111218	C(9)
0.1224	1.552379	8088.256	12556.04	C(10)
0.0000	42.98784	0.005169	0.222212	C(11)

E+576.84

Determinant residual covariance

Equation: $CT = C(1) + C(2) * YD + C(3) * YD(-1)$
 Observations: 31

480194.9	Mean dependent var	0.981632	R-squared
601519.8	S.D. dependent var	0.980320	Adjusted R-squared
E+111.99	Sum squared resid	84384.82	S.E. of regression
0.674281	Durbin-Watson stat		

Equation: $S = C(4) + C(5) * YD$
 Observations: 28

281454.5	Mean dependent var	0.921144	R-squared
393390.9	S.D. dependent var	0.918112	Adjusted R-squared
E+113.29	Sum squared resid	112573.4	S.E. of regression
0.893303	Durbin-Watson stat		

Equation: $I = C(6) - C(7)*IN$

Observations: 32

261773.4	Mean dependent var	0.456212	R-squared
321534.9	S.D. dependent var	0.438086	Adjusted R-squared
E+121.74	Sum squared resid	241025.6	S.E. of regression
0.152963	Durbin-Watson stat		

Equation: $T = C(8) + C(9)*Y$

Observations: 32

108185.0	Mean dependent var	0.987922	R-squared
141682.1	S.D. dependent var	0.987519	Adjusted R-squared
E+097.52	Sum squared resid	15828.45	S.E. of regression
1.194747	Durbin-Watson stat		

Equation: $M = C(10) + C(11)*Y$

Observations: 32

222796.5	Mean dependent var	0.982978	R-squared
283789.9	S.D. dependent var	0.982411	Adjusted R-squared
E+104.25	Sum squared resid	37637.31	S.E. of regression
1.165298	Durbin-Watson stat		

:

$$C_t = 24118.4 + 0.428 \cdot Y_{d,t} + 32629.24 \cdot Y_{d,t-1}$$

: (2SLS)

/

:

Estimation Method: Two-Stage Least Squares

Sample: 1970 2001

Instruments: YD IN Y X G R E C

.Prob	t Statistic	Std. Error	Coefficient	
0.1991	1.289150	19449.45	25073.26	C(1)
0.0024	3.080916	0.123536	0.380605	C(2)
0.2970	1.046102	0.139693	0.146133	C(3)
0.2435	1.170264-	27881.95	32629.24-	C(4)
0.0000	17.42747	0.018140	0.316127	C(5)
0.7620	0.303308-	70729.13	21452.72-	C(6)
0.0000	5.016828-	8803.505	44165.67-	C(7)
0.4008	0.842242	3513.089	2958.870	C(8)
0.0000	49.53573	0.002245	0.111218	C(9)
0.1347	1.503084	8353.515	12556.04	C(10)
0.0000	41.62279	0.005339	0.222212	C(11)

E+577.13

Determinant residual covariance

Equation: $CT = C(1) + C(2) * YD + C(3) * YD(-1)$

Observations: 31

480194.9	Mean dependent var	0.981510	R-squared
601519.8	S.D. dependent var	0.980189	Adjusted R-squared
E+112.01	Sum squared resid	84664.01	S.E. of regression
	0.616606	Durbin-Watson stat	

Equation: $S = C(4) + C(5) * YD$

Observations: 28

281454.5	Mean dependent var	0.921144	R-squared
393390.9	S.D. dependent var	0.918112	Adjusted R-squared
E+113.29	Sum squared resid	112573.4	S.E. of regression
	0.893303	Durbin-Watson stat	

Equation: $I = C(6) - C(7)*IN$

Observations: 32

261773.4	Mean dependent var	0.456212	R-squared
321534.9	S.D. dependent var	0.438086	Adjusted R-squared
E+121.74	Sum squared resid	241025.6	S.E. of regression
	0.152963	Durbin-Watson stat	

Equation: $T = C(8) + C(9)*Y$

Observations: 32

108185.0	Mean dependent var	0.987922	R-squared
141682.1	S.D. dependent var	0.987519	Adjusted R-squared
E+097.52	Sum squared resid	15828.45	S.E. of regression
	1.194747	Durbin-Watson stat	

Equation: $M = C(10) + C(11)*Y$

Observations: 32

222796.5	Mean dependent var	0.982978	R-squared
283789.9	S.D. dependent var	0.982411	Adjusted R-squared
E+104.25	Sum squared resid	37637.31	S.E. of regression
	1.165298	Durbin-Watson stat	

من خلال هذا الجدول نستنتج ان :

$$C_t = 25073.26 + 0.38 \cdot Yd_t + 0.146 \cdot Yd_{t-1}$$

$$S_t = -32629.24 + 0.316 \cdot Yd_t$$

$$I_t = -21452.72 - 44165.67 \cdot \hat{u}_t$$

$$T_t = 2958.87 + 0.111 \cdot Y_t$$

$$M_T = 12556.04 + 0.222 \cdot Y_t$$

:(W2SLS)

2SLS

Estimation Method: **Weighted Two-Stage Least Squares**

Sample: 1970 2001

Instruments: YD IN Y X G

.Prob	t-Statistic	Std. Error	Coefficient	
0.1767	1.356455	18484.41	25073.26	C(1)
0.0014	3.241766	0.117407	0.380605	C(2)
0.2726	1.100717	0.132762	0.146133	C(3)
0.2262	1.214440-	26867.72	32629.24-	C(4)
0.0000	18.08535	0.017480	0.316127	C(5)
0.7545	0.313255-	68483.18	21452.72	C(6)
0.0000	5.181358-	8523.957	44165.67	C(7)
0.3856	0.869864	3401.533	2958.870	C(8)
0.0000	51.16029	0.002174	0.111218	C(9)
0.1224	1.552379	8088.256	12556.04	C(10)
0.0000	42.98784	0.005169	0.222212	C(11)

E+577.13

Determinant residual covariance

(Equation: $CT = C(1) + C(2) * YD + C(3) * YD(-1)$)

Observations: 31

480194.9	Mean dependent var	0.981510	R-squared
601519.8	S.D. dependent var	0.980189	Adjusted R-squared
E+112.01	Sum squared resid	84664.01	S.E. of regression
	0.616606	Durbin-Watson stat	

Equation: $S = C(4) + C(5) * YD$

Observations: 28

281454.5	Mean dependent var	0.921144	R-squared
393390.9	S.D. dependent var	0.918112	Adjusted R-squared
E+113.29	Sum squared resid	112573.4	S.E. of regression
	0.893303	Durbin-Watson stat	

Equation: $I = C(6) - C(7) * IN$

Observations: 32

261773.4	Mean dependent var	0.456212	R-squared
321534.9	S.D. dependent var	0.438086	Adjusted R-squared
E+121.74	Sum squared resid	241025.6	S.E. of regression
	0.152963	Durbin-Watson stat	

Equation: $T = C(8) + C(9) * Y$

Observations: 32

Estimation Method: **Three-Stage Least Squares**

.Prob	t -Statistic	Std. Error	Coefficient	
0.5384	0.616454	12511.51	7712.776	C(1)
0.0000	12.05886	0.033793	0.407505	C(2)
0.0002	3.752353	0.035856	0.134545	C(3)
0.5767	0.559210-	18964.60	10605.18-	C(4)
0.0000	19.82543	0.015055	0.298477	C(5)
0.1124	1.595481-	50709.47	80905.97-	C(6)
0.0000	6.781285-	6162.568	41790.13-	C(7)
0.6633	0.436160	2679.634	1168.749	C(8)
0.0000	56.69063	0.001990	0.112813	C(9)
0.3589	0.919878	7276.853	6693.818	C(10)
0.0000	47.97176	0.004741	0.227450	C(11)

E+573.92

Determinant residual covariance

(Equation: CT= C(1) + C(2) *YD+ C(3) *YD(-1

Observations: 31

480194.9	Mean dependent var	0.980487	R-squared
601519.8	S.D. dependent var	0.979093	Adjusted R-squared
E+112.12	Sum squared resid	86975.93	S.E. of regression
	0.635844	Durbin-Watson stat	

Equation: S = C(4) + C(5)*YD

Observations: 28

281454.5	Mean dependent var	0.918138	R-squared
393390.9	S.D. dependent var	0.914990	Adjusted R-squared
E+113.42	Sum squared resid	114699.2	S.E. of regression
	0.903322	Durbin-Watson stat	

Equation: $I = C(6) - C(7)*IN$

Observations: 32

261773.4	Mean dependent var	0.399196	R-squared
321534.9	S.D. dependent var	0.379169	Adjusted R-squared
E+121.93	Sum squared resid	253346.4	S.E. of regression
	0.130203	Durbin-Watson stat	

Equation: $T = C(8) + C(9)*Y$

Observations: 32

108185.0	Mean dependent var	0.987714	R-squared
141682.1	S.D. dependent var	0.987305	Adjusted R-squared
E+097.65	Sum squared resid	15963.66	S.E. of regression
	1.194467	Durbin-Watson stat	

Equation: $M = C(10) + C(11)*Y$

Observations: 32

222796.5	Mean dependent var	0.982422	R-squared
283789.9	S.D. dependent var	0.981836	Adjusted R-squared
E+104.39	Sum squared resid	38247.70	S.E. of regression
	1.150214	Durbin-Watson stat	

:

$$C_t = 7712.77 + 0.407 \cdot Y_{d,t} + 0.134 \cdot Y_{d,t-1}$$

$$S_t = 10605.18 + 0.298 \cdot Y_{d,t}$$

$$I_t = -80905.97 - 41790.13 \cdot \hat{u}_t$$

$$T_t = 1168.74 + 0.112 \cdot Y_t$$

$$M_T = 6693.81 + 0.227 \cdot Y_t$$

: (GMM-CS) /

Instruments: YD IN Y X G C

White Covariance

.Prob	t-Statistic	Std. Error	Coefficient	
0.0000	6.812708	3680.367	25073.26	C(1)
0.0000	11.33956	0.033564	0.380605	C(2)
0.0002	3.818402	0.038271	0.146133	C(3)
0.0000	6.027694-	5413.221	32629.24-	C(4)
0.0000	116.9101	0.002704	0.316127	C(5)
0.0919	1.694793-	12658.02	21452.72-	C(6)
0.0000	34.89323-	1265.737	44165.67-	C(7)
0.0000	5.890982	502.2711	2958.870	C(8)

0.0000	699.6263	0.000159	0.111218	C(9)
0.0000	8.097992	1550.512	12556.04	C(10)
0.0000	434.7983	0.000511	0.222212	C(11)

E+577.13

1.024167

Determinant residual covariance

J-statistic

$$\text{Equation: CT} = C(1) + C(2) * YD + C(3) * YD(-1)$$

Observations: 31

480194.9	Mean dependent var	0.981510	R-squared
601519.8	S.D. dependent var	0.980189	Adjusted R-squared
E+112.01	Sum squared resid	84664.01	S.E. of regression
		0.616606	Durbin-Watson stat

$$\text{Equation: S} = C(4) + C(5) * YD$$

Observations: 28

281454.5	Mean dependent var	0.921144	R-squared
393390.9	S.D. dependent var	0.918112	Adjusted R-squared
E+113.29	Sum squared resid	112573.4	S.E. of regression
		0.893303	Durbin-Watson stat

$$\text{Equation: I} = C(6) - C(7) * IN$$

Observations: 32

261773.4	Mean dependent var	0.456212	R-squared
321534.9	S.D. dependent var	0.438086	Adjusted R-squared
E+121.74	Sum squared resid	241025.6	S.E. of regression
		0.152963	Durbin-Watson stat

$$\text{Equation: T} = C(8) + C(9) * Y$$

Observations: 32

108185.0	Mean dependent var	0.987922	R-squared
141682.1	S.D. dependent var	0.987519	Adjusted R-squared
E+097.52	Sum squared resid	15828.45	S.E. of regression
		1.194747	Durbin-Watson stat

Equation: $M = C(10) + C(11) * Y$

Observations: 32

222796.5	Mean dependent var	0.982978	R-squared
283789.9	S.D. dependent var	0.982411	Adjusted R-squared
E+104.25	Sum squared resid	37637.31	S.E. of regression
		1.165298	Durbin-Watson stat

:

$$C_t = 25073.26 + 0.38 \cdot Y_{d_t} + 0.146 \cdot Y_{d_{t-1}}$$

$$S_t = -32629.24 + 0.316 \cdot Y_{d_t}$$

$$I_t = -21452.72 - 44165.67 \cdot \hat{u}_t$$

$$T_t = 2958.87 + 0.111 \cdot Y_t$$

$$M_T = 12556.04 + 0.222 \cdot Y_t$$

:(GMM- TS)

/

. (non singulière)

:

(J)

GMM-CS

-

GMM- TS

(non singulière)

2WLS 2SLS - WLS OLS : -1

. **GMM-CS**

: **-2**

c(8)-c(6)-c(4)-c(2)- : WLS-WLS2-2SLS -OLS •

. **c(1)- c(10)-**

.**c(11)-c(8)-c(6)-c(4)- c(1)- : 3SLS •**

. **GMM-CS**

: **-3 - 3- III**

: **WLS OLS -1**

GMM-CS -2

: **-2**

(R²) *

: **(DW) - •**

الشكل (11) : مقارنة

GMM1		3SLS		2WLS		2SLS		WLS		OLS		
DW	R ²	DW	R ²	DW	R ²	DW	R ²	DW	R ²	DW	R ²	
0.81	0.94	1.2	0.93	0.81	0.94	0.81	0.94	0.93	0.93	0.93	0.93	1
1.91	0.37	1.9	0.37	1.91	0.37	1.91	0.37	1.91	0.37	1.91	0.37	2
1.98	0.9	1.91	0.9	1.98	0.9	1.98	0.9	1.98	0.9	1.98	0.9	3
1.36	0.83	1.44	0.83	1.36	0.83	1.36	0.83	1.36	0.83	1.36	0.83	4
1.78	0.69	-	0.69	1.78	0.69	1.78	0.69	1.78	0.69	1.78	0.69	5

(DW) : _____
 (DW) - (R²)

(GMM-CS) :

GMM-CS OLS : اظهر التحيز الشكل (12) :

GMM-CS:	OLS :	
25073.26	24118.4	C(1)
0.38	0.428	C(2)
0.146	0.092	C(3)
0.316	0.316	C(5)
0.111	0.111	C(9)
0.222	0.222	C(11)

() : _____
 :

GMM-CS

OLS

-1

C(2)

Y_d

: -4 - 3- III

2SLS

$$M_t - T_t - I_t - S_t - CT_t \quad :$$

:

$$Yd_t - X_t - G_t - IN_t - Y_t$$

.



: -1 - IV

: -1- 1- IV

- -

.

1970

:(Ydt)

-1-1- 1- IV

:(03)

2001

:

-

:

:(38)

Date: 03/19/05 Time: 14:06
 Sample: 1970 2001
 Included observations: 32

Autocorrelation	Partial Correlation	AC	PAC	Q-Stat	Prob	
		1	0.861	0.861	26.037	0.000
		2	0.712	-0.117	44.399	0.000
		3	0.607	0.091	58.221	0.000
		4	0.510	-0.053	68.325	0.000
		5	0.394	-0.119	74.568	0.000
		6	0.273	-0.085	77.697	0.000
		7	0.174	-0.025	79.021	0.000
		8	0.102	0.009	79.494	0.000
		9	0.044	-0.005	79.584	0.000
		10	-0.017	-0.051	79.598	0.000
		11	-0.066	-0.016	79.825	0.000
		12	-0.100	-0.016	80.364	0.000
		13	-0.127	-0.034	81.287	0.000
		14	-0.149	-0.014	82.627	0.000
		15	-0.167	-0.028	84.420	0.000
		16	-0.186	-0.046	86.776	0.000
		17	-0.207	-0.052	89.870	0.000
		18	-0.226	-0.048	93.855	0.000
		19	-0.244	-0.042	98.856	0.000
		20	-0.260	-0.040	104.99	0.000
		21	-0.274	-0.040	112.42	0.000
		22	-0.281	-0.023	121.04	0.000

TSP-eviews

)

:_____



(AC)
 (PICK) (PAC)
 p = 1

DICKEY-FULLER

(03) (RACINES UNITAIRES – UNIT ROOT

: ()

$$Y_{dt} = \Phi_1 Y_{d,t-1} + bt + c + \varepsilon_t \quad (03)$$

$$Y_{dt} = \Phi_1 Y_{d,t-1} + c + \varepsilon_t \quad (02)$$

$$Y_{dt} = \Phi_1 Y_{d,t-1} + \varepsilon_t \quad (01)$$

() Dickey-Fuller

(03) : (1)

tsp-eviews

$$H_1 : |\Phi_1| \geq 1$$

$$H_0 : |\Phi_1| \leq 1$$

Critical Value* %1

4.2949-

0.898519

ADF Test Statistic

Critical Value %5

3.5670-

H_1

H_0

%5 %1

t_{tab}

$t_c = 0.898$:

($|\Phi_1| \leq 1$)

:

Econometric Views - [Equation: UNTITLED Workfile: ISM]

File Edit Objects View Procs Quick Options Window Help

View Procs Objects Print Name Freeze Estimate Forecast Stats Resids

LS // Dependent Variable is D(YD)
 Date: 07/12/05 Time: 19:21
 Sample(adjusted): 1972 2001
 Included observations: 30 after adjusting endpoints
 Convergence achieved after 3 iterations

Variable	Coefficient	Std. Error	t-Statistic	Prob.
C	138042.9	64700.03	2.133583	0.0418
AR(1)	0.545103	0.157185	3.467917	0.0017

R-squared	0.300463	Mean dependent var	130363.1
Adjusted R-squared	0.275479	S.D. dependent var	188851.2
S.E. of regression	160747.8	Akaike info criterion	24.03952
Sum squared resid	7.24E+11	Schwarz criterion	24.13294
Log likelihood	-401.1610	F-statistic	12.02645
Durbin-Watson stat	1.756255	Prob[F-statistic]	0.001713

Inverted AR Roots	.55
-------------------	-----

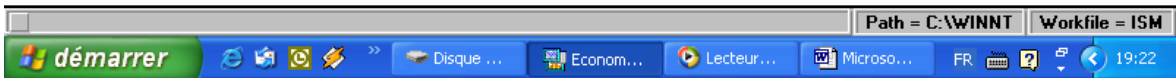

$$\Delta Yd_t = 138042.9 - 0.545 \Delta Yd_{t-1}$$

: (

: (1 -

: Y d t-1

| 3.46 | > 1.96

: (2-

H0 :

H1 :

:

الشكل (41) :

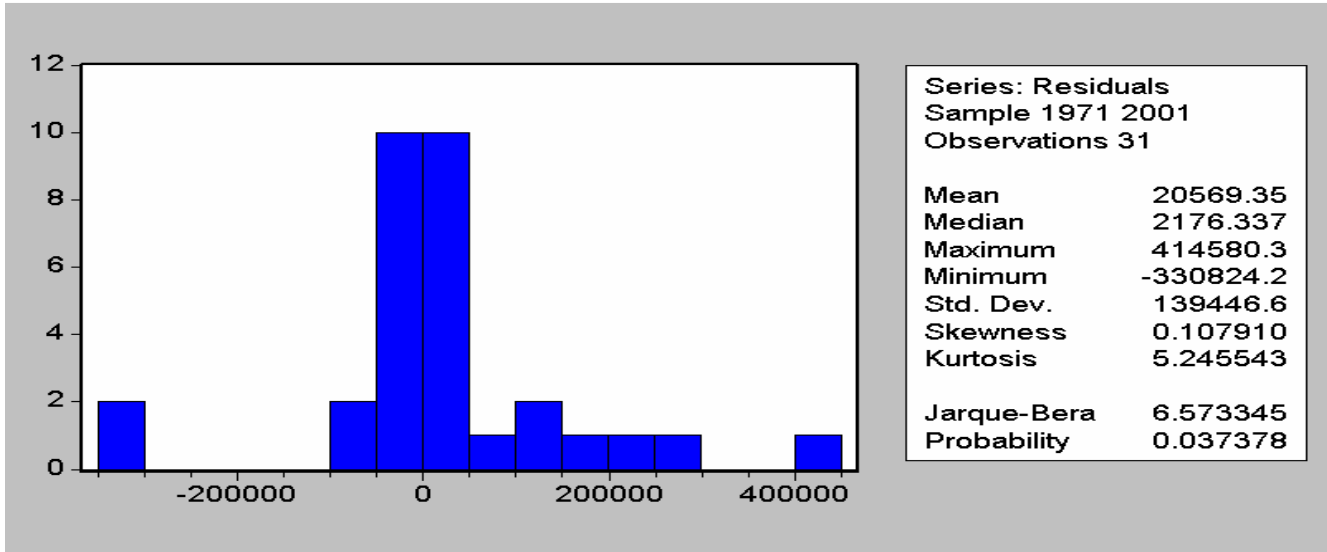

المصدر : من اعداد الباحث (باستخدام البرنامج)

$$B_1^{1/2} = 0.107 \quad : \text{ (SKEWNESS) } \quad *$$

$$1.96 > V_1 = |B_1^{1/2} - 0| / \sqrt{6/n} = 0.107 / \sqrt{6/30}$$

$$: \quad B_2 = 5.245 \quad : \text{ (kurtosis) } \quad *$$

$$: \quad 1.96 < V_2 = |B_2 - 0| / \sqrt{24/n} = 5.245 / \sqrt{24/30}$$

$$: \text{ (JB) jaque - bera } \quad *$$

$$\chi_2(2) = 5.99 < S = 6.573 \quad : \quad \text{bera-jaque}$$

()

: () (3 -



ε_t

LM

EIEWS

$y d_{t-1}$

:

ARCH- LM

$$nR^2 = 3.067 < \chi_2(2) = 5.99$$

:(AUTOCORRELATION)

(4 -

()

DW= 1.83

:

(DW)

-

$du < DW < 2$:

: (

t+1 :

T+h. t+2

: 2002

T+1

$$\Delta Yd_t = 138042.9 - 0.545 \Delta Yd_{t-1}$$

$$\Delta Yd_{(2002)} = 138042.9 - 0.545 \Delta Yd_{(2001)1} :$$

$$= 138042.9 - 0.545 * 193194$$

: (2003) t+2

$$: \Delta Yd_{(2003)} = 138042.9 - 0.545 \Delta Yd_{(2002)t}$$

$$= 138042.9 - 0.545 * 32752,17$$

:

(05)

: (13)

()		
4459854,208	2002	T+1
5066394,380	2003	T+2
5755424,016	2004	T+3
6538161,682	2005	T+4
7427351,670	2006	T+5

() :

chow

: (2001 -1999)

Chow Forecast Test: Forecast from 1999 to 2001

0.000773	Probability	7.597338	F-statistic
0.000277	Probability	18.97255	Log likelihood ratio

$$F_C = 7.593 :$$

$$F_t = F_{(k+1; n-2(k+1))} = F_{(3; 25)} = 2.99 :$$

$$H_1 \quad H_0 \quad F_C > F_t$$

2001

:(YT) - 2- 1-1- IV

: (03) 2001 1970

: (

:

: (42)

Date: 01/04/20 Time: 04:27
Sample: 1970 2001
Included observations: 32

Autocorrelation	Partial Correlation	AC	PAC	Q-Stat	Prob	
		1	0.723	0.723	18.353	0.000
		2	0.564	0.087	29.899	0.000
		3	0.426	-0.019	36.715	0.000
		4	0.327	0.006	40.874	0.000
		5	0.385	0.286	46.857	0.000
		6	0.261	-0.251	49.710	0.000
		7	0.170	-0.073	50.963	0.000
		8	0.122	0.070	51.636	0.000
		9	0.045	-0.049	51.732	0.000
		10	-0.016	-0.219	51.745	0.000
		11	-0.072	0.046	52.013	0.000
		12	-0.103	0.062	52.590	0.000
		13	-0.097	-0.050	53.129	0.000
		14	-0.114	-0.078	53.914	0.000
		15	-0.130	0.081	54.993	0.000
		16	-0.146	-0.029	56.449	0.000

المصدر: من إعداد الباحث (باستعمال البرنامج)

(AC)

P = 1

(PICK)

(PAC)

(03)

DICKEY-FULLER

$$Y_t = \Phi_1 Y_{t-1} + bt + c + \varepsilon_t$$

:

3.6661-

Critical Value* %1

2.366868 ADF Test Statistic

2.9627-

Critical Value %5

H_1 H_0

%5 %1 t_{tab}

$t_c = 2.366$:

$$(|\Phi_1| \leq 1)$$



EVIWES

AR (1)

Y_T

$$\Delta Y_t = 146425.7 - 0.541 \Delta Y_{t-1}$$

: () (

: (1 -

$$1.96 < |55.691| :$$

Y_{t-1}

: (2-

H_0 :

H_1 :

:

$$B^{1/2}_1 = -0.01 : (\text{SKEWNESS}) *$$

$$1.96 > V_1 = |B^{1/2}_1 - 0| / \sqrt{6/n} = 0.01 / \sqrt{6/30}$$

$$: B_2 = 5.02 : (\text{kurtosis}) *$$

$$: 1.96 < V_2 = |B_2 - 0| / \sqrt{24/n} = 5.02 / \sqrt{24/30}$$

: (JB) jaque - bera *

$$\chi^2(2) = 5.99 > S = 5.319 : \text{bera-jaque}$$

()

(JB) jaque - bera

: () (3 -



ε_t

LM

EViews

Y_{t-1}

ARCH- LM

:

$$nR^2 = 6.971 > \chi_2(2) = 5.99$$

:(AUTOCORRELATION)

(4 -

()

$$DW = 1.759$$

(DW)

-

$$du < DW < 2$$

: (

t+1 :

T+h. t+2

: 2002 T+1

$$\begin{aligned} \Delta Y_{(2002)} &= 146425.7 - 0.541 \Delta Y_{(2001)} : \Delta Y_t = 146425.7 - 0.541 \Delta Y_{t-1} \\ &= 146425.7 - 0.541 * 144987.02 \end{aligned}$$

:

:(14)

()		
48124720,35	2002	T+1
54573432,876	2003	T+2
61886272,882	2004	T+3
70179033,448	2005	T+4
79583023,930	2006	T+5

() : _____

: (X_T) -3-1-1-IV

: X_T (

:

: (43)

Included observations: 32

Autocorrelation	Partial Correlation	AC	PAC	Q-Stat	Prob	
		1	0.783	0.783	21.490	0.000
		2	0.517	-0.246	31.178	0.000
		3	0.453	0.390	38.892	0.000
		4	0.419	-0.158	45.697	0.000
		5	0.304	-0.023	49.419	0.000
		6	0.173	-0.107	50.669	0.000
		7	0.084	-0.047	50.976	0.000
		8	0.046	0.026	51.071	0.000
		9	0.011	-0.047	51.076	0.000
		10	-0.052	-0.048	51.211	0.000
		11	-0.094	0.019	51.674	0.000
		12	-0.098	-0.024	52.196	0.000
		13	-0.118	-0.068	52.995	0.000
		14	-0.123	0.091	53.911	0.000
		15	-0.123	-0.114	54.883	0.000
		16	-0.136	0.026	56.135	0.000

المصدر: من اعداد الباحث (باستعمال البرنامج)

(03) DICKEY-FULLER

$$X_t = \Phi_1 X_{t-1} + bt + c + \varepsilon_t$$

:

3.6661- Critical Value* %1 1.657383 ADF Test Statistic

2.9627-

Critical Value %5

H_1

H_0

%5

%1

t_{tab}

$t_c = 1.657$

:

$$و . (| \Phi_1 | \leq 1)$$

: (

$$AR(1) \quad \Delta^2 X_t$$

:

$$\Delta^2 X_t = -0.590 \Delta^2 X_{t-1}$$

: (

:

:

(1-

$$1.96 < | 15.994- | :$$

$$\Delta^2 X_{t-1}$$

:

(2-

H_0 :

H_1 :

:

$$B^{1/2}_1 = 1.39 \quad : \text{ (SKEWNESS) } \quad *$$

$$1.96 < V_1 = | B^{1/2}_1 - 0 | / \sqrt{6/n} = 1.39 / \sqrt{6/30}$$

$$: \quad B_2 = 6.60 \quad : \quad : \text{ (kurtosis) } \quad *$$

$$: \quad 1.96 < V_2 = | B_2 - 0 | / \sqrt{24/n} = 6.60 / \sqrt{24/30}$$

$$: \text{ (JB) jaque - bera } \quad *$$

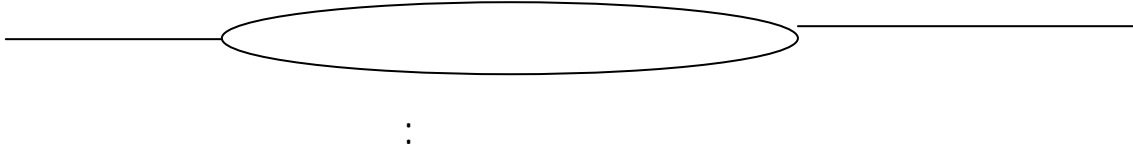

: (15)

()		
47170579,376	2002	T+1
107716208,04	2003	T+2
1211223666.25	2004	T+3
1566332892.3	2005	T+4
1556998662.9	2006	T+5

()

_____ :

:(IN)

- 4-1- 1- IV

:

(

:

الشكل (44) :

Date: 10/14/04 Time: 20:43
Sample: 1970 2001
Included observations: 32

Autocorrelation	Partial Correlation	AC	PAC	Q-Stat	Prob
1	0.844	0.844	25.004	0.000	
2	0.705	-0.025	43.047	0.000	
3	0.580	-0.031	55.685	0.000	
4	0.494	0.060	65.173	0.000	
5	0.426	0.016	72.487	0.000	
6	0.315	-0.185	76.648	0.000	
7	0.226	0.003	78.879	0.000	
8	0.161	0.023	80.048	0.000	
9	0.101	-0.059	80.527	0.000	
10	0.027	-0.110	80.562	0.000	
11	-0.050	-0.040	80.690	0.000	
12	-0.112	-0.037	81.376	0.000	
13	-0.154	-0.025	82.731	0.000	
14	-0.188	-0.032	84.866	0.000	
15	-0.226	-0.045	88.127	0.000	
16	-0.241	0.026	92.078	0.000	

المصدر : من اعداد الباحث (باستخدام البرنامج)

$$IN_t = \Phi_1 IN_{t-1} + bt + c + \varepsilon_t \quad :$$

(03)



:

3.6661- Critical Value* %1 1.461724- ADF Test Statistic

2.9627- Critical Value %5

. ($|\Phi_1| \leq 1$) H_1 H_0

%1 عند $\Phi_3 = 10.61$ $F_3 = 0.207$:

DICKEY-FULLER

. H_1^3 H_0^3

:

$H_1^2 : (c, b, \Phi_1) \neq (0, 0, 1)$

$H_0^2 : (c, b, \Phi_1) = (0, 0, 1)$

(V) $\Phi_2 = 8.21$ $F_2 = 0.49$:

: H_1^2 H_0^2 عند %1

$$IN_t = \Phi_1 IN_{t-1} + c + \varepsilon_t$$

:

4.2949- Critical Value* %1 1.937575- ADF Test Statistic

3.5670- Critical Value %5

. H_1 H_0

$H_1^2 : (c, \Phi_1) \neq (0, 1)$

$H_0^1 : (c, \Phi_1) = (0, 1)$:

%1 عند (I V) $\Phi_1 = 7.88$ $F_1 = 0.75$:

$\Phi_1 \neq 1$: $\Phi_1 \neq 1$ $\Phi_1 = 1$ ، H_1^1 H_0^1

()AR(1)

: (

:

$$IN_t = 0.992 * IN_{t-1} \\ (25.894)$$

:

:

(



: (1 -

: IN_{t-1}

$$1.96 < |25.894|$$

: (2-

H0 :

H1 :

:

$B^{1/2}_1 = 0.774$: (SKEWNESS) *

$$1.96 > V_1 = |B^{1/2}_1 - 0| / \sqrt{6/n} = 0.774 / \sqrt{6/30}$$

: $B_2 = 7.907$: (kurtosis) *

$$1.96 < V_2 = |B_2 - 0| / \sqrt{24/n} = 7.907 / \sqrt{24/30}$$

: (JB) jaque - bera *

$$\chi_2(2) = 5.99 < S = 34.20 : \text{bera-jaque}$$

()

: () (3 -

ε_t

LM

EIEWS

IN_{t-1}

:

ARCH- LM

$$nR^2 = 0.042 < \chi_2(2) = 5.99$$

:(AUTOCORRELATION)

(4 -



()

DW= 1.3 : (DW) -

du < DW < 2 :

: (

t+1 :

: (2003) t+1 T t+2

$$IN_{(2003)} = 0.992 * IN_{(2002)} = 0.992 * 8 = 7,936$$

:

: (16)

(%)		
7,936	2002	T+1
7,872	2003	T+2
7,809	2004	T+3
7,747	2005	T+4
7,685	2006	T+5

() : _____

:(G)

-5-1- 1- IV

: (

:

: (45)

Date: 10/14/04 Time: 21:50
Sample: 1970 2001
Included observations: 32

	Autocorrelation	Partial Correlation	AC	PAC	Q-Stat	Prob
1	0.807	0.807	22.863	0.000		
2	0.679	0.079	39.576	0.000		
3	0.538	-0.087	50.437	0.000		
4	0.390	-0.118	56.352	0.000		
5	0.254	-0.079	58.950	0.000		
6	0.136	-0.045	59.727	0.000		
7	-0.030	-0.234	59.765	0.000		
8	-0.044	0.266	59.852	0.000		
9	-0.058	0.064	60.012	0.000		
10	-0.075	-0.058	60.289	0.000		
11	-0.088	-0.078	60.692	0.000		
12	-0.099	-0.047	61.225	0.000		
13	-0.109	-0.010	61.906	0.000		
14	-0.118	-0.140	62.747	0.000		
15	-0.127	0.077	63.780	0.000		
16	-0.138	0.026	65.070	0.000		

المصدر: من اعداد الباحث (باستخدام البرنامج)

G

(03) DICKEY-FULLER

$$G_t = \Phi_1 G_{t-1} + bt + c + \varepsilon_t$$

:

3.6661- Critical Value* %1 3.337493 ADF Test Statistic

2.9627- Critical Value %5

H_1 H_0

AR(1)

:

(

:

$$\Delta G_t = 0.761 \Delta G_{t-1}$$

:

:

(



(1 -

: ΔG_{t-1}

$$1.96 < | 76.854 |$$

(2-

H0 :

H1 :

:

$B^{1/2}_1 = 0.810$: (SKEWNESS) *

$$1.96 > V_1 = | B^{1/2}_1 - 0 | / \sqrt{6/n} = 0.810 / \sqrt{6/30}$$

: $B_2 = 4.265$: (kurtosis) *

$$1.96 < V_2 = | B_2 - 0 | / \sqrt{24/n} = 4.265 / \sqrt{24/30}$$

: (JB) jaque - bera *

$$\chi_2(2) = 5.99 > S = 5.463 : \text{bera-jaque}$$

()

(jaque - bera)

: () (3 -

ε_t

EViews

G_{t-1}

: ARCH- LM

$$nR^2 = 3.634 < \chi_2(2) = 5.99$$

:(AUTOCORRELATION) (4-

()

DW= 1.561 : (DW) -

du < DW < 2 :

: (

t+1 :

T+h. t+2

: 2002 T+1

$$\Delta G_{(2002)}=0.761 \Delta G_{(2001)} : \Delta G_t=0.761 \Delta G_{t-1}$$

$$= 0.761*1806301$$

:

:(17)

()		
2050151,635	2002	T+1
2326922,105	2003	T+2
2641056,589	2004	T+3
2997599,229	2005	T+4
3402275,125	2006	T+5

() : _____

:

(20) : تنبؤات المتغيرات الخارجية 2002 - 2006

2006	2005	2004	2003	2002	/
7427351.67	6538161.68	5755424.01	5066394.38	4459854.20	Yd
79583023.93	70179033.44	61886272.88	54573432.87	48124720.35	Y

%7.68	%7.74	%7.80	%7.87	%7.93	IN
119521223942.24	20898582859.3	3668134858.4	635801466.76	94649337.5	X
3402275.12	2997599.22	2641056.58	2326922.10	2050151.63	G

() :

. % IN R \$1/ E :

: -2-1-IV

()

2SLS

. ()

: (2002 :) T+1

$$C_{(2002)} = -89886.09 + 0.302 \cdot Yd_{(2002)} + 0.374 \cdot Yd_{(2001)}$$

$$S_{(2002)} = 537383.3 + 0.222 \cdot Yd_{(2002)}$$

$$I_{(2002)} = -537207.3 + 312721.9 \cdot IN_{(2002)}$$

$$T_{(2002)} = -47141.77 + 0.11 \cdot Y_{(2002)}$$

$$M_{(2002)} = 458394.4 + 0.182 \cdot Y_{(2002)}$$

:

$$C_{(2002)} = -89886.09 + 0.302 * 4459854.20 + 0.374 * 18172774$$

$$= 8053607,294$$

$$S_{(2002)} = 537383.3 + 0.222 * 4459854.20 = 98654171,3$$

$$I_{(2002)} = -537207.3 + 312721.9 * 7.93 = 1942494,23$$

$$T_{(2002)} = -47141.77 + 0.11 * 48124720.35 = 5293719,2$$

$$M_{(2002)} = 458394.4 + 0.182 * 48124720.35 = 9217093,44$$

$$M^S_{(2002)} = 2808.535 + 9370.821 * 10.25_t + 13131.32 * 66.79$$

$$= 975900,31305$$

:

(21) : تنبؤات المتغيرات الداخلية 2002 – 2006

M	T	I	S	C	
9217093,44	5293719,2	1942494,23	98654171,3	8053607,294	2002
10390759,182	6616274,383	1923914,053	1662122,852	3108150,483	2003
11721696,064	6760348,246	1902023,52	1815087,430	3543083,459	2004
13230978,486	7672551,908	1883260,206	1505255,192	6189695,896	2005
14942504,755	8706991,53	1864496,892	2186255,370	2153174,114	2006

() : _____
: EVIEWS

الشكل (48) :

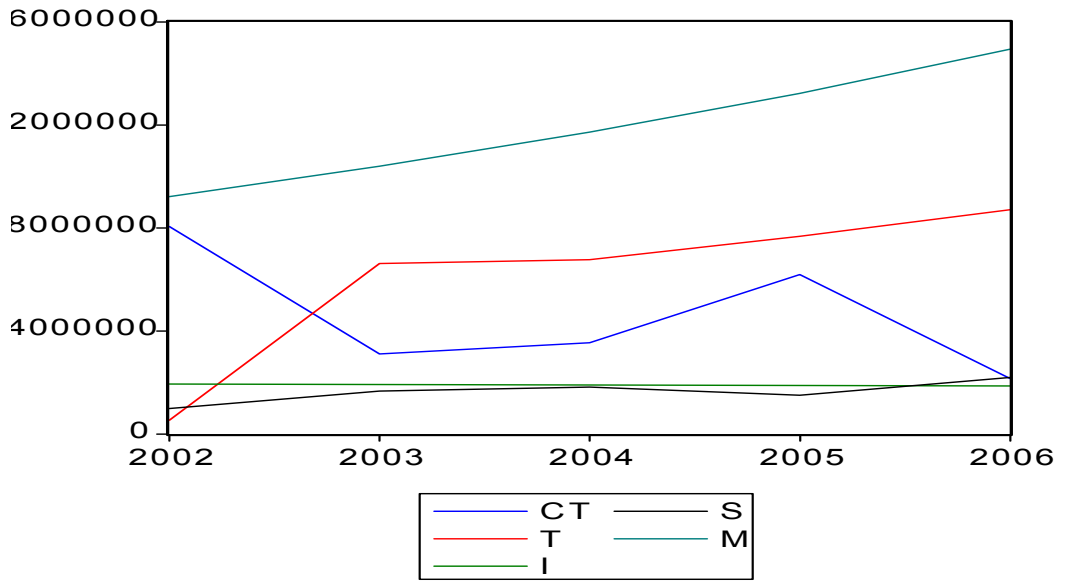

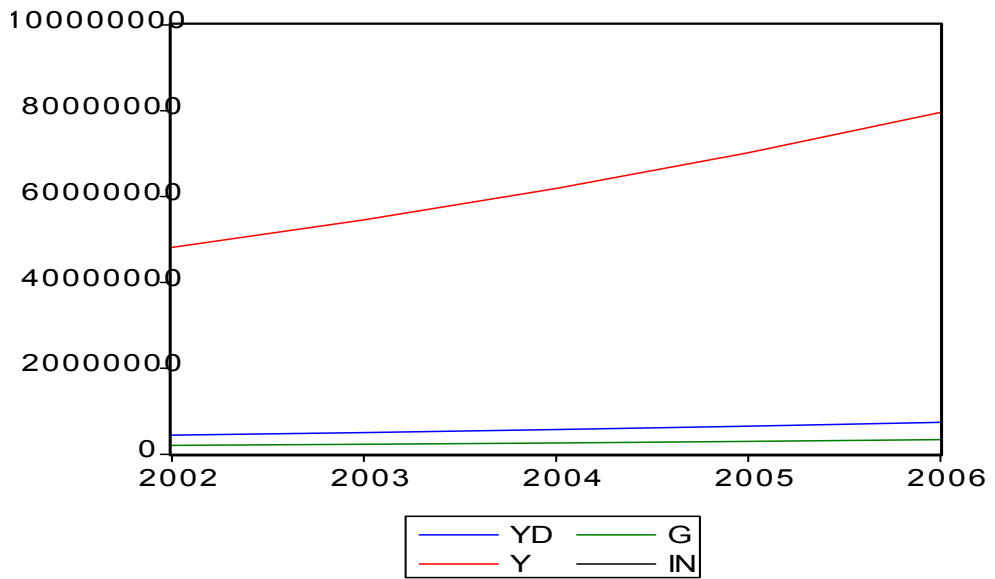

(TSP-EVIEWS) : _____
 : , - 3- 1 - IV

: % 13.6 1.136 *
 t $Y_{d_{t+1}} - Y_{d_t} / Y_{d_t} = 0.136$ $Y_{d_{t+1}} = 1.136 * Y_{d_t}$
 . t+1
 : % 13.4 1.134 -2
 $Y_{t+1} - Y_t / Y_t = 0.134$ $Y_{t+1} = 1.134 Y_t$
 % 0.08 0.992 -3
 .% 13.5 1.135
 : : *



(22.2 %) 0.222 -

(11 %) 0.11 -

(18.2 %) 0.182 -

: 2003 2002 (1) ()

2003 2002 : (22)

IN	G	T	/
6.63	1540900	1570300	2002
6.5	1786800	1518200	2003

⏟
:

:

: %17.12 2002 2001 IN -

2003 2002 $IN_{(2002)} / IN_{(2001)} = 6.63 / 8 = 0.82875$

.2003 2002

1.96%



2002 2001

(1) T

-

. 2003 2002

G

-

2003 2002

(2003-2002-2001)

.
:

2003 2002

... G - X - Y - Yd

(2001-1970)

Y

)

((2006-2002)

:

% 100 %0

IN

.(%0)

(% 100)

:

- 2-VI

:

- *

) :

-

- (

:

(1) - نقصد هنا بالضرائب الوعاء الضريبي وليست الضرائب ومعدلاتها



-
-
-

. ... - -

:

(-) -
(...)

:

- -

(ex . APSI) ANDI -ANSEJ :

- :

. ... -

% 17 TVA

.

.

:

-

.

-



:-*

...

(1)

- - :

() :

..... - :

(1)

)

.(

:(2)

*

*

(1)- عبد الناصر العبادي واخرون ، مرجع سابق ، ص 17
(2) - بن عبد العزيز فطيمة : مرجع سابق ، ص 130



()

:

- 1 - 2 - IV

2001/12

» « (1) : « ... » : « »

15.9

7.5

% 58

(PIB

% 2.1)

100

10

%7.78

% 40.75

(1) - التقرير قدم للجزائر بعد توقيعها الاتفاق مع الاتحاد الاوروبي لكنها امتنعت عن نشره .



60

10

40

1000

5000

1.12

% 3.42 %

(1)

:

:

*

-2002

2004-2003

-

-

:

2005

(2)

-

•

-

.

-

:

. ...

-

-

(1) - ص. حفيظ ، انعكاسات اتفاق الشراكة على الجزائر في جريدة "الخبر" ، عدد 290 ، 23 /04/ 2004 ، ص 3
(2) - رفع اسعار الوقود يعتبر من التزامات الجزائر نحو الانضمام الى OMC والمرتبط برزنامة زمنية معينة



- :

... -

.

- :

.

- :

... .

.

•

(2004 \$ 30

\$ 29.3)

1.5

. 2010

2

(19)

•

1996 \$ 33)

، (1)

(2003 \$ 23.20

(1)

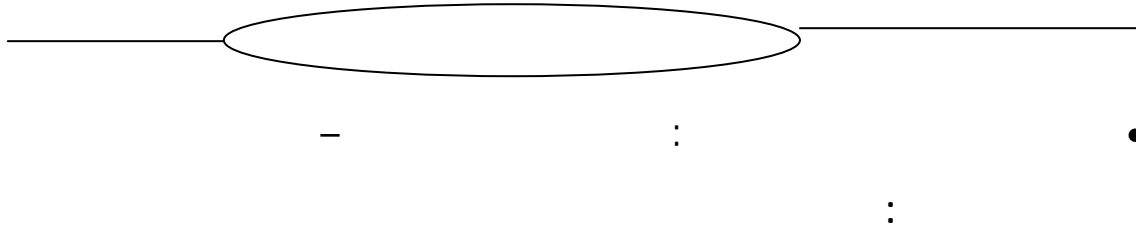

-2-2 - IV

) :

(



- -) : ()
(... - - -

: (

:
() : -1

: -2

: -3

- - -) : -4
(...

: -5



- - :

() ' ...

-

...

... - - - :

.

:

. ...

-

-

-6

:

() /1

/2

) (...) /3

(... /4

.

(2(

" "

"

(1) - ونعني بذلك الشركات المتعددة الجنسيات التي تتعدد فروعها في العالم وليست الدولة الوطنية



- :
(- -) - -

"

."

:

:

جدول (23) : تقديرات تطور عدد السكان حسب الجنس (1999 - 2001)

	%		%		/
29965000	49,46	14820000	50,54	15145000	1999
30416000	49,45	15041000	50,55	15375000	2000
30879000	49,51	15288000	50,49	15591000	2001

(-) : _____

:

7.8 2003) -

2004 - % 17.94 - 1.4

() %19

- - -)

(... -

(2) - احمد بن نعمان : نفسية المجتمع الجزائري ، شركة دار الأمة ، الجزائر ، ط 2 ، 1997 ، ص ص 105 - 182

() -

. : -

()

: (24)

القيمة : في 1000 (2001 - 1999)

	%	55	%	54-35	%	34-20	%	19-0	/
29965	9,04	2709	17,41	5218	26,32	7887	47,22	14151	1999
30416	9,05	2754	17,99	5473	26,83	8163	46,11	14026	2000
30879	9,29	2871	18,46	5701	27,27	8421	44,96	13886	2001

() : _____

(19 - 0) 2001 1999

:

جدول (25) : تطور السكان المشتغلين حسب الطبقات

	%		%		
8690855	38,32	3330176	61,68	5360679	2000
8568221	41,12	3522514	58,88	5045707	2001

() : _____

:

-

(1) ... ()

)

. (800

:

: (26)

(2001-1999)

	%		%		%		%		%	/	
157565	25,01	39409	47,72	75194	1,25	1978	20,4	32142	5,61	8842	1999
145481	17,86	25996	49,25	71657	1,76	2563	25,04	36443	6,06	8822	2000
178512	20,81	37210	50,33	89846	1,38	2474	21,32	38061	6,11	10921	2001

المصدر: من إعداد الباحث (بناء على معطيات لديوان الوطني للإحصائيات)

-

:

... ..

-

-

:

*

،2000

، 1

: - (1)

ص 12



. - - - : *

-

....

.

)

)

(

)

(

(

:

(... -)

)

(... -) (

.

.



:

•

•

•

()

(ANSEJ-CNAC-CACOPATH)

:

‘

(-)

-1

(... - -)

‘

()

-2

)

-3

2002 218620 2001 194273

(- 04 - % 12.5

- - :

-4

:

(.... -)

.

:

(1)

، 3

11

، (- -) :

- () - (- -)

(1)

،

(2)

7 14 (1999 -97)

،

- (3)

(4)

(5)

(1) - ص.حفيظ : 11 مؤسسة تدخل بورصة الجزائر عام 2005 في الخبر ، 2004/11/28 ، ص 02



(6)

. CITY BANK :

(.... -) (7)

(8)

:

-1

-

-

()

(25)

(1)

,

-2

,

(1)- سليم قلالة : المشهد الاوربي في (حصة في دائرة الضوء) ، التلفزيون الجزائري ، 29 / 12 / 2004



(PME)

-3

-4

-5

-6

-7

(... -)

-8

... - - - :

(1)

-9

- 10

-)

-11

(... - -

... - - :

-12

(1) - بوقنة عبد الفتاح : مشروع استراتيجية تنمية المؤسسات الصغيرة والمتوسطة في مجلة فضاءات، وزلرة المؤسسات الصغيرة والمتوسطة، الجزائر، ص 06



-13

. ... - :

-14

(..... - - -)

..... - - -

‘

•

- - :

‘

•

:

•

- -

. - - :

. ()

()

: TSP-EIEWS

..... 2SLS – 3SLS – GMM (CS – TS) - 2WSLS

: ()

) - - -

. ... - (

:

. - - -

- - :

- - -

(-)

.

: _____

2003 2002

:

-1

(.) - -2

%100 %0

:

()

.

-

-

.

(.... - -)

.....
()
.
-) :
... - - ()
- -)
.(...

()
3 100 2)

.(2010

-

)

(

-

:

-1

-2

-3

- GRANGER

-4

:

: () *

*

.(:)

*

(..... -)

.

⋮

-I

⋮ *

.1994	:	-1
.1997	:	-2
. 1997 2	:	- 3
.2004/08	:	- 4
.2003 .. 2	:	-5
.2002 ، 2	:	-6
(:)	:	-7
.1983	:	-8
(:)	:	-8
.2001	1 (
1994	:	-9
()	:	-10
.1981	:	-11
، (:)	:	-11
.1982	:	-12
.2000	1 :	-12
2 ()	:	-13

1998

	:	-14
	:	.1990
.1981	.. 2 :	-15
	.1985 .. :	-16
.1992	.. () :	-17
. 1995	.. :	-18

: _____ *

- 19 - BENDIB RACHID: **économétrie**, 1^{er} édit, OPU, Alger, 2001
 20 – BOURBONNIE REGIS: **économétrie**, 5^{eme} édit, DUNOD, France, 2003
 21- HAMDANI HOCINE : **statistique descriptive**, 1^{er} édit, OPU, Alger, 1999.
 22- TIRAZA MICHEL et BOURBONNIE REGIE: **économétrie des séries temporelles** . 1^{er} édit, France, 1997

: _____ - II
 : _____ *

	:	-23
	:	.1997/96
	:) :	- 24
09	‘ (. 1985/
	‘ - - :	-25
	1997 /96 ‘ ‘ ‘	

	:	<u> </u>	*
	:	- 26	
	:	99 - 89	
	:	.2003	
	:	- 27	
	:	.2003	
	:	- 28	
	:	.2003	
	:	- III	
	:	<u> </u>	*
	:	- 27	
	:	.2003	
	:	- 28	
	:	2000	
	:	، 1	
	:	/04/23 ، 290	- 29
	:	. 2004	
	:	2005	- 30
	:	(2004 15 09) 293	
	:	2004/11/28 ، 2005 11	- 32
	:	، () ، 4 ، 1	- 31
	:	. 2003	
	:	، 1	- 32

			2000
، ()	:		- 33
		.2001/06	،
)	:		-34
		.2000/03	، (
، ()	:		-35
		. 2001/12	،
2004/12/ 29 ، ، ،	:		-36

: *

37 - CNES : **les équilibres financiers et la régulation** , 03/2004 Alger
(www.cnes.dz) .

38 - ministre de finance : **statistiques financiers** , 06/2004
([www.google..com / ministre de financer](http://www.google..com/ministre%20de%20financer) + Algérie)

39 - ONS : **statistiques sociales et économiques** , 05/2004 , (www.ons.dz) .

: - VI

40 - **MATLAB** : ver (anglais) 6^{eme} édit , 2002.

41 - **MS- EXCEL** : ver WIN XP ; 2003

42 - **STATISTICA** : ver (français) 1997 .

43 - **TSP . EVIEWS** : ver 01 , 1997

.

BUDGET DE L'ETAT.

(EN MILLIARDS DE DA).

	<u>1994</u>	<u>1995</u>	<u>1996</u>	<u>1997</u>	<u>1998</u>	<u>1999</u>
<u>Recettes budgétaires</u>	477.2	611.7	824.0	933.6	784.3	972.8
Recettes fiscales	176.2	242.0	286.9	312.9	338.5	338.9
Recettes ordinaires	10.6	10.7	14.0	17.9	15.7	14.6
Fiscalité pétrolière	222.2	336.1	496.2	570.8	378.7	560.1
Recettes exceptionnelles	68.2	22.9	26.8	32.1	51.4	55.2
Fonds de concours, dons et legs	0.0	0.0	0.0	0.0	0.0	3.9
<u>Dépenses budgétaires</u>	566.3	759.6	888.3	940.9	970.7	1078.8
Dépenses de fonctionnement	330.4	473.7	590.5	665.2	725.0	824.4
Dépenses d'équipement	235.9	285.9	297.8	275.7	245.7	254.4
Solde budgétaire	-89.1	-147.9	-64.3	-7.3	-186.4	-106.0
Solde budgét. hors dette pub.	-89.1	-147.9	-64.3	27.8	-101.3	9.9
Solde budgét. hors FA et dette publique	33.4	0.6	60.1	105.8	-101.3	9.9

FA= Fonds d'assainissement des entreprises publiques.

	<u>2000</u>	<u>2001</u>	<u>2002</u>	<u>2003</u>
<u>Recettes budgétaires</u>	1138.9	1395.8	1570.3	1518.2
Recettes fiscales	3632.4	405.3	478.2	524.5
Recettes ordinaires	16.5	15.1	66.0	22.2
Fiscalité pétrolière	720	840.6	916.4	836.1
Autres recettes	80	223.0	102.8	135.4
<u>Dépenses budgétaires</u>	1160.4	1519.3	1540.9	1786.8
Dépenses de fonctionnement	841.4	1056.8	1038.6	1173.8
Dépenses d'équipement	318.9	462.5	502.3	612.9
Solde budgétaire	-21.4	-123.5	29.4	-268.6
Solde budgét. hors dette pub.	-21.4	-123.5	29.4	-268.6
Solde budgét. hors FA et dette publique	-21.4	-123.5	29.4	-268.6

BALANCE DES PAIEMENTS.

(EN MILLIARDS DE US.\$).

	<u>1994</u>	<u>1995</u>	<u>1996</u>	<u>1997</u>	<u>1998</u>
Exportation de biens et snf	9.59	10.94	13.96	14.81	10.90
Hydrocarbures	8.61	9.73	12.64	13.25	9.75
Autres marchandises	0.29	0.53	0.57	0.50	0.37
Services	0.69	0.68	0.75	1.07	0.78
Importation de biens et snf	11.09	12.39	11.24	10.28	10.94
Biens	9.16	10.20	9.09	8.13	8.63
Services	1.93	2.19	2.15	2.15	2.31
Solde compte courant	-1.82	-2.52	0.93	3.01	-0.92
Solde compte capital	1.94	1.15	0.50	0.36	-0.25
Réserves brutes	2.64	2.11	4.23	8.05	6.84
Ratio du service de la dette ext.(%)	48.70	42.69	31.48	33.15	47.80

SITUATION MONETAIRE.

(EN MILLIARDS DE DA).

	<u>1994</u>	<u>1995</u>	<u>1996</u>	<u>1997</u>	<u>1998</u>	<u>1999</u>
Crédits à l'économie	305.8	565.6	776.8	741.3	906.2	1150.7
Crédits à l'Etat	468.5	401.6	280.5	423.7	723.2	847.9
Circulation fiduciaire	223.0	249.8	290.9	337.6	435.9	440.0
Dépôts à vue	252.8	269.3	298.2	333.9	422.9	465.2
Dépôts à terme	247.7	280.5	326.0	409.9	766.1	884.2
Masse monétaire M2	723.5	799.6	915.1	1081.5	1592.5	1789.4
Ratio de liquidité (%)	49.1	40.7	36.7	39.8	46.0	46.0

	<u>2000</u>	<u>2001</u>	<u>2002</u>	<u>2003</u>
Crédits à l'économie	993.7	1078.4	1266.8	1378.9
Crédits à l'Etat	677.4	569.7	578.7	420.8
Circulation fiduciaire	484.5	577.2	664.7	781.3
Dépôts à vue	563.7	661.3	751.6	849.7
Dépôts à terme	974.3	1235.0	1485.2	1723.9
Masse monétaire M2	2022.4	2473.5	2901.5	3354.9
Ratio de liquidité (%)	49.3	58.4	65.1	65.2

TAUX DE CHANGE.

(DA/US.\$)

	<u>1994</u>	<u>1995</u>	<u>1996</u>	<u>1997</u>	<u>1998</u>	<u>1999</u>
Taux de change moyen	35.09	47.68	54.77	57.73	58.74	66.64
Taux de change fin de période	42.89	52.18	56.19	58.41	60.35	69.32

	<u>2000</u>	<u>2001</u>	<u>2002</u>	<u>2003</u>
Taux de change moyen	75.29	77.26	79.69	77.37
Taux de change fin de période	75.34	77.82	79.72	72.61

VARIATION DES PRIX A LA CONSOMMATION.

(EN %)

	<u>1994</u>	<u>1995</u>	<u>1996</u>	<u>1997</u>	<u>1998</u>	<u>1999</u>
Inflation (moyenne annuelle)	29.05	29.78	18.69	5.73	4.95	2.64
Inflation (glissement sur 12 mois)	38.48	21.83	15.08	6.05	3.94	1.21

	<u>2000</u>	<u>2001</u>	<u>2002</u>	<u>2003</u>
Inflation (moyenne annuelle)	0.34	4.23	1.42	2.59
Inflation (glissement sur 12 mois)	0.12	7.56	-1.55	3.96

TAUX D'INTERETS.

(EN % PAR AN).

	<u>1994</u>	<u>1995</u>	<u>1996</u>	<u>1997</u>	<u>1998</u>	<u>1999</u>
Récompte (fin de période)	15.00	14.00	13.00	11.00	9.50	8.50
Récompte (moyen)	14.13	14.58	13.67	12.21	9.63	9.17
Base bancaire (fin de période) (*)	18.50	17.00	15.00	13.00	8.50	8.50
Base bancaire (moyen) (*)	17.63	18.00	16.33	14.00	9.25	8.50

	<u>2000</u>	<u>2001</u>	<u>2002</u>	<u>2003</u>
Récompte (fin de période)	6.00	6.00	5.50	4.50
Récompte (moyen)	7.13	6.00	5.50	4.92
Base bancaire (fin de période) (*)	8.50	8.00	6.50	6.50
Base bancaire (moyen) (*)	8.50	8.00	6.63	6.50

(*) Taux débiteurs.

LA DETTE EXTERIEURE

(EN MILLIONS DE US.\$)

	1992	1993	1994	1995	1996	1997	1998	1999	2000	2001
- Dette à MLT	25.886	25.024	28.850	31.317	33.230	31.060	30.262	28.140	25.088	22.311
- Dette à CT	792	700	636	256	421	162	212	175	173	260
- Total	26.678	25.724	29.486	31.573	33.641	31.222	30.474	28.315	25.261	22.571

	2002	2003
- Dette à MLT	22.540	23.203
- Dette à CT	102	150
- Total	22.642	23.353

SECTEUR REEL.

	UNITES	<u>1993</u>	<u>1994</u>	<u>1995</u>	<u>1996</u>	<u>1997</u>	<u>1998</u>
Le PIB	Mrds DA	1.165,0	1.487,4	2004,9	2.570,0	2.780,2	2.830,4
Le PIB	Mrds US.\$	49,9	42,4	42,0	46,9	48,2	48,2
Croissance du PIB	%	-2,1	-0,7	3,9	4,3	1,1	5,1
PIB par habitant	US.\$	1.856	1.542	1.498	1.643	1.658	1.633

	UNITES	<u>1999</u>	<u>2000</u>	<u>2001</u>	<u>2002</u>	<u>2003</u>
Le PIB	Mrds DA	3.248,2	4.098,8	4.235,6	4.455,4	5.149,4
Le PIB	Mrds US.\$	48,7	54,4	54,8	55,9	66,6
Croissance du PIB	%	3,2	2,4	2,1	4,1	6,8
PIB par habitant	US.\$	1.627	1.790	1.775	1.783	2.093

Probability	F-Statistic	Obs	Null Hypothesis:
0.53559	0.64333	26	IN does not Granger Cause S
0.53038	0.65371		S does not Granger Cause IN

Probability	F-Statistic	Obs	Null Hypothesis:
E-063.5	24.2508	26	YD does not Granger Cause S
E-052.7	18.0806		S does not Granger Cause YD

Probability	F-Statistic	Obs	Null Hypothesis:
0.20363	1.69721	30	Y does not Granger Cause MS
0.00891	5.73526		MS does not Granger Cause Y

Probability	F-Statistic	Obs	Null Hypothesis:
0.08877	2.67223	30	IN does not Granger Cause MS
0.21209	1.65102		MS does not Granger Cause IN

Probability	F-Statistic	Obs	Null Hypothesis:
0.01528	2142.04	6	TIR does not Granger Cause MS
0.16940	16.9236		MS does not Granger Cause TIR

Probability	F-Statistic	Obs	Null Hypothesis:
0.05672	154.906	6	TCR does not Granger Cause MS
0.76492	0.35455		MS does not Granger Cause TCR

II

III.....

IV

V.....

VII.....

أ.....

01..... : - I

02..... -1 - I

07..... -2 -I

09..... -3 -I

09..... - 1 -3 - I

10..... -1- 1-3 - I

11..... - 2- 1 -3- I

12..... - 3 -1 -3-I

13..... - 4 -1-3- I

21..... - 2 -3- I

26..... : -II

27..... - 1-II

27..... - 1 -1 - II

28..... - 2 - 1 - II

29..... - 3 - 1 - II

29..... (SURE) - 4 - 1 - II

102.....	- 2 -3 - III
121.....	- 3 -3 - III
123.....	- 4 -3 - III
124.....	: <u> </u> - IV
125.....	- 1 - IV
125.....	- 1 - 1 - IV
125.....	- 1 -1 - 1 - IV
126.....	- 2 - 1 - 1 - IV
133.....	- 3 - 1 - 1 - IV
137.....	- 4- 1 - 1 - IV
140.....	- 5 - 1 - 1 - IV
149.....	- 2 - 1 - IV
152.....	، - 3 - 1 - IV
155.....	-2 - IV
158..	- 1 - 2 - IV
162	-2-2 - IV
171.....	- 3 - 2 - IV
175.....	
182.....	
188.....	